

Battery Shut-Off Wrenches

YZ-TH600

YZ-TH800

YZ-TH900

YZ-TH950

Instruction Manual



Thank you for purchasing YOKOTA products.

Before use, please read this Instruction Manual carefully
and use the product properly after fully understanding the Manual.

Please be sure to keep this Instruction Manual.

 **YOKOTA INDUSTRIAL CO., LTD**

Head Office/Factory 5-55 Nishiiwata 3-chome, Higashiosaka City, 578-0947 Osaka, Japan

TEL.: +81-6-6788-1381 FAX. +81-6-6781-4519

<http://www.yokota-kogyo.co.jp>

Table of contents

■	1 . SAFETY CARE	3
■	2 . GLOSSARY	9
■	3 . OVERVIEW OF THE PRODUCT	エラー! ブックマークが定義されていません。
■	4 . SPECIFICATION	エラー! ブックマークが定義されていません。
■	5 . EACH PART DESCRIPTION	13
■	6 . PREPARATION BEFORE USE	16
■	7 . PAIRING	17
■	8 . USE	19
■	9 . PERFORMANCE INSPECTION MODE	29
■	1 0 . BUZZER SOUNDS AND LED LIGHTING PATTERNS	30
■	1 1 . ACCESSORIES	32
■	1 2 . MAINTENANCE AND INSPECTION	32
■	1 3 . CAUTION ON DISPOSAL	32
■	1 4 . TROUBLESHOOTING	33

■ 1. Safety Care

 **Warning :** Please be sure to thoroughly read this Instruction Manual and fully understand the Instruction to use correctly, before installation, operation, maintenance and inspection.

■ In this Instruction Manual, safety precautions prefix either of the following safety alert pictograms. All are important items relating to safety and must be observed.

 **Warning** . . . Cases where mishandling induces a potentially hazardous situation, which, if not avoided, could result in a death or serious personal injury.

 **Caution** . . . Cases where mishandling induces a potentially hazardous situation, which, if not avoided, may result in minor or moderate personal injury or property damage.

※ Notes: Even items described in “  Caution” may lead to serious consequences depending on circumstances.

■ Retain this Instruction Manual in a place where it is always available for anyone who needs to use it and read repeatedly.

■ In cases where you lost this Instruction Manual or the warning label affixed to the product or made it dirty, immediately contact us or your YOKOTA distributor to obtain the Manual or the warning label, and then properly retain the Manual or replace the warning label.

■ In cases where you transfer or rent this product, be sure to attach this Instruction Manual to it.

If you have any questions on the product or the contents in this manual, please contact us or our distributor where you purchased the product.

 **Warning** ■ Please be sure to thoroughly read this Instruction Manual and fully understand the instruction to use correctly, before using this product.

● Installation, Environment



Warning

- This product is for the indoor exclusive use. Do not use it in rain, in a damp place and a wet place.
- Dark or messy workplace could result in accidents. To avoid that, pay careful attention to lighting and make efforts to keep the workplace clean and tidy.
- To protect yourself, wear personal protective equipment such as a hard hat(helmet), safety glasses, safety shoes. And depending on work environment, wear earplugs, a dust mask etc.
- Dress properly. When working, do not wear loose clothes or jewelry such as necklace. If your hairs are long, bundle them with rubber ring to avoid contact with the tool and wear a protective cover such as cap. Otherwise, it may cause injury.
- Do not use this product in a place likely to be exposed to water, direct sunlight, much dust, heat, oil, or moving parts of industrial equipment. Otherwise, it may cause fire, electric shock, or accident.
- Do not operate the tool in explosive atmospheres, such as in the presence of flammable liquids, gases or dusts. There is a fear of fire. Other than that, do not use in a place with electrical and mechanical harmful atmosphere.
- Use it away from things that generate large noise (welding machine · DC motor with brush etc.).
- Do not place inflammable materials nearby. There is a fear of fire.
- Do not make the foreign object such as metal pieces, invaded to the product. There is a fear of fire.
- Use the battery charger at rated supply voltage (AC 100-240 V).
Do not use DC power supply, engine generator, or power transformer. Failure to do so may result in heat generation and fire.
- Be sure to fully insert the power plug of the battery charger. Failure to do so may result in electric shock or fire due to heat generation.
- If you do not use the product, unplug the battery charger.
Wipe out dust or stain accumulated on the power plug or receptacle with a dry cloth.
Failure to do so may result in electric shock or fire.
- Do not insert or remove the power plug of the battery charger from the receptacle with wet hand. There is a fear of electric shock.
- Charge the battery pack in well-ventilated place. While charging, do not cover the ventilation openings on the battery pack and battery charger with cloth. Doing so may result in rupture or fire.
- In cold location or before starting the work in winter season, use fully charged battery pack.
If the battery pack is at low level, it may not be able to be used due to its protective function.
- Place the charger in a place of 0 to 40 ° C. Do not charge the battery pack at less than 0°C or more than 40°C. Doing so may result in rupture or fire.
- If this product is suspended by balancer etc., mount YOKOTA-specified hanger to the product.
Use the threaded holes for mounting hanger only for mounting YOKOTA-specified parts.

● Operation, Driving



Warning

- To protect yourself, wear personal protective equipment such as a hard hat(helmet), safety glasses, safety shoes. And depending on work environment, wear earplugs, a dust mask etc.
- Dress properly. When working, do not wear loose clothes or jewelry such as necklace. If your hairs are long, bundle them with rubber ring to avoid contact with the tool and wear a protective cover such as cap. Otherwise, it may cause injury.
- Use the power tool for tightening of screws. Use for other purposes may cause accident.
- Avoid the use of the power tool by persons inexperienced for handling. Otherwise, it may result in injury and/or accident.
- Use the tool within its capacity. Unreasonable use of the tool in overload could result in the damage or failure of the tool.
- Use the tool with proper tightening capability for the object to be tightened. If the capability is too big for the object, the object or work piece may be broken or damaged and the broken pieces may cause injury.
- Keep the tool away from the moving parts of plant facility. Otherwise, the tool may be entangled or pinched and it may be damaged.
- Handle the power tool carefully. Abuse may cause accident and/or malfunction. Do not give impacts on it by throwing or dropping it.
- Do not use a socket with much wobble.
- After installation of the attachment, pull it lightly and make sure that it does not come off.
Note that unsecure installation may cause damage on the attachment and/or early malfunction of the product as well as accidents.
- If attachments for hand tools are used, there is a risk of breakage which may cause the accident such as scattering of fragments. Therefore be sure to use attachments for power tools.
- Use socket stoppers specified by Yokota or socket makers. Do not use wire, a nail and others as a substitute for a socket stopper, which can cause serious accidents.
- Fix the work piece (object to be tightened) securely. If the fixing is insufficient, the work piece (object to be tightened) may be dispersed and it may cause injury.
- NEVER bring your hand or a cloth and so on to the moving part of the tool.
- Before attachment of the battery pack to the tool, make sure that the tools such as pins used for capability adjustment are removed and the throttle lever is in OFF position. Otherwise, the tool may accidentally operate and it may result in injury.
- Be sure to check the direction of reverse lever of the power tool before operation.
Be sure to switch the rotational direction while the power tool stops.
- When running the tool at no load, be sure that the tip tool (like socket, bit and so on) was removed without fail and be careful around the surroundings. The operation at no load for a long time will result in the part seizure, early wear and heat generation of the motor.

- Engage the tip tool (like socket, bit and so on) securely to the fastener before pulling the throttle lever.
- Pull the throttle lever of the tool slowly to start. Sudden start may cause accident or malfunction.
- Working in unusual positions is dangerous. Hold the tool securely and carry out working in stable posture, preparing for accidental movement at the same time.
- Be careful about burn injury. During use and immediately right after tightening, metal parts, tip tool, bolts and nuts may be hot.
- Do not touch metal parts, tip tool, bolts and nuts immediately right after tightening.
Also, do not touch the exhaust port of the tool during use. There is a fear of burn injury.
- Do not make the foreign object such as metal pieces, invaded to the product. There is fear of fire.
- Do not stick the pin, bar and so on into the inlet or exhaust of the cooling fan nor plug the hole.
- Do not remove the parts from the tool. If you use such tool as the mounted parts or screws removed, it may result in accident.
- Do not pinch the power supply cord of the battery charger in the object to be tightened or do not contact the cord with rotating parts. Otherwise, it may be damaged and result in accident.
- Use the exclusive battery pack and battery charger only.
- Do not disassemble or modify the battery pack and battery charger.
Doing so may result in heat generation, fire, electric shock, or injury.
- Do not throw the battery pack into fire or heat it.
Doing so may result in rupture or release of hazardous substances.
- Do not drive a nail or give an impact such as fall on the battery pack or battery charger.
Doing so may result in heat generation, fire, electric shock, and/or injury.
- Do not short-circuit the terminals of the battery pack.
Do not carry or store the battery pack with metal object such as nail. Doing so may result in smoking, ignition, or rupture.
- If the battery pack gets hot during its use, stop using it immediately and after detaching the battery pack from the tool, contact our distributor or sales representative where you have purchased.
- If the battery pack leaks, stop using it and contact our distributor or sales representative where you have purchased.
- If the electrolyte of the battery gets in your eyes, do not pass your hand over your eyes, but flush them with a plenty of clean water and seek medical attention. Failure to do so may result in loss of vision.
- If the electrolyte of the battery comes in contact with body part or clothes, rinse with a plenty of clean water and seek medical attention. Failure to do so may result in dermal inflammation or injury.
- Noise might be regulated under laws and regulations of the country or regions where the product is used.
The tool must be used at noise levels below those prescribed by them, not to trouble the surroundings. Install sound insulation walls, depending on the necessity.
If noise levels at the operator's position exceed 85dB (A), be sure to use earplugs.
Even if noise levels are not more than 85dB (A), it is recommended to use earplugs.
- When the tool receives damage such as breakage or if you feel uneasiness during the use, stop using the tool immediately and after removing the battery pack, ask repair or inspection to YOKOTA or

YOKOTA-authorized or designated servicing factory via our distributor or sales representative.

If any accident or problem occurs due to the customer's intended action such as disassembly of this product, we shall not be liable for such trouble.

- Before doing the following actions, remove the battery pack from the tool. Otherwise, it may accidentally operate and result in injury.
 - Storage or repair of the tool
 - Replacement of socket and bit
 - Adjusting the relief valve
 - Other cases in which the operation of the tool may result in danger.
- Remove the tool's battery pack when not using it.



Caution

- Operate at the correct scaffold and environment. Work in an unreasonable posture is very dangerous.
- Do not use the tool when you are tired or under influence of drugs, alcohol or medication.
A moment of inattention during the use of tool may result in serious personal injury.
- When plugging and unplugging the setting device, remove the battery pack. Otherwise, it may result in the breakdown.
- When plugging and unplugging the setting device, treat the connector carefully.
Otherwise, it may result in the breakdown.

● Maintenance, Inspection, and Repair



Warning

- Before operation, be sure to carry out the following checking. If you fail to do it, it may cause not only degradation of performance or trouble but also danger. Do not use when there is abnormality.
 - No damage on the tool body
 - No problem on operation of throttle lever or reverse lever
 - No loosening or damage of screws for the tool
 - No abrasion or damage on the tip tool, etc.
 - Normal room/play or wobbling for connection between the tool and the tip tool or the connection between the tool and battery pack
- Confirm the torque periodically by the torque wrench after tightening the bolt, nut and so on.
Confirm the retightening torque value and the output torque value in daily inspection.
- When using hanger, do the following inspection periodically:
 - No damage of hooking parts such as balancer, and correct mounting condition.
 - No damage or abnormality on the hanger of the tool ,
- Remove metal objects (clock, ring etc) before maintenance, inspection and repair. There is a danger of electric shock or injury.
- Only qualified service person is allowed to do maintenance and repair the tool. Repair or maintenance performed by non-qualified person or qualified person's work beyond the qualification range may result

in serious personal injury of the user.

- NEVER make any modification to the tool. Doing so could result in accidents. In addition, never use the spare part other than the genuine one.
- Do not hold the power supply cord for battery charger for carrying or pull the cord to unplug it. In addition, be careful to avoid stepping on or being caught by the cord, and/or damage by excessive force. Damage of the power supply cord may result in accident.
- If the tool operates for approximately half of work rate with fully charged battery pack, it means the expiry of its operating life. Buy a new battery pack.
- If the tool is not used for long time, fully charge the battery pack before storage.
Even during storage, fully charge the battery pack more than once within one year of last charge. Otherwise, over-discharge of the battery pack may prevent it from charging.
- Do not store the battery pack in a place reaching over 50°C. Doing so may cause deterioration of the battery pack and result in smoking or fire.
- Do not short-circuit the terminals of the battery pack. Do not carry or store the battery pack with metal object such as nail. Doing so may result in smoking, ignition, or rupture.
- Attach an anti-short-circuit cap after the battery pack is removed from the tool or the battery charger or when the tool is not used. Failure to do so may result in short circuit of the terminals of the battery pack and fire.
- Wipe out the dirt on the housing of the tool by using the dry and soft cloth.
Do not use the chlorinated solvent, gasoline, thinner and the like, which works to melt the plastic.
- Store the product in the dry area, where children or untrained person can not get access to.

● Disposal



Caution

- Dispose of it according to the method of sorting, laws and regulations, in the used area.
- Lithium-ion battery used in this battery pack is recyclable and valuable resource.

If it is no longer used, bring it to our distributor, etc. where you have purchased.

● Others



Caution

- Keep anyone, particularly children, other than those involved in the work away from the work site. Not doing so could induce a hazardous situation.
- Do not touch the oil plug of the tool except repairing. It causes early oil leakage.
- Using a tool which has been in storage for more than 6 months may cause oil leakage because of damage to the seal part on the impulse mechanism. We will inspect the tool which has been in storage for more than 6 months.
- When using in cold place or in winter season, warming up for the tool is required.
Run the tool for about 0.5 to 1 second several times by loading the main shaft. If the warming up is not carried out, generating pulses may not be stable.

■ 2. Glossary

(1) Value

A value at which the tool will shutoff once it reaches during rundown

(2) Tightening Value

The result value of a rundown

(3) Tightening Pulse No.

Number of pulses after reaching the display start value until shut-off.

(4) Display Start Value

Threshold value to judge OK or NG. At less than this value, no judgement is made.

(5) Switch Value

A value of switching point of motor speed from MID to HIGH rpm.

(6) Cut Value

The value at which the tool will automatically shut off during rundown

(7) Max Value

Maximum value to judge OK or NG.

(8) LOW Speed:

Free speed when the throttle lever of the tool is pulled slightly to the first step (at right/left rotation)

(9) MID. Speed

Free speed when the throttle lever of the tool is pulled to full. (only at right rotation)

※In case of reverse rotation, this setting is not valid. (Valid for low and high speed only).

(10) HIGH Speed:

Free speed after the Middle to High switch value is achieved. (at right rotation)

Free speed when the throttle lever of the tool is pulled to full. (at left rotation)

(11) MIN Pulse

Minimum pulse number for tightening to judge OK or NG.

(12) MAX Pulse

Maximum pulse number for tightening to judge OK or NG.

(13) Average Number

The arithmetic average from the preset number of pulses.

(14) Slow Error Pulses

The number of pulses in excess of the preset number (70 fixed) of pulses, including those less than display start value, to judge.

(15) Value Judgement before average

Value over judgement as a base of the value before the arithmetic average

■ 3. Overview of The Product

This product is a shut-off tool which is used for bolt tightening, and will stop automatically according to the tightening conditions. For tightening parameter setting, use the specially prepared programing console PC-1 and cable CC-1 for the product.

By connecting YZ-TH to PC-1 via CC-1, the reference of rundown results and the test mode can be possible in addition to the tightening parameter setting.



※[Setting device] described in this instruction manual, means programing console (PC-1) and special cable (CC-1) in connection.

- ⚠ The battery pack should be detached from YZ-TH when connecting/disconnecting the setting device to or from YZ-TH..
Connecting/disconnecting the setting device, in the state that YZ-TH runs, can be a cause of failure.
- ⚠ When connecting and disconnecting the setting device to or from YZ-TH, treat the connector carefully. Otherwise, it may result in the breakdown.
- ⚠ Close the shutter of the cable connecting port on the YZ-TH till it locks, when the setting device is not connected.

■ 4. Specification

• TOOLS

Models		YZ-TH600A	YZ-TH600	YZ-TH800A	YZ-TH800	YZ-TH900	YZ-TH950
Bolt Capacity		M6	M6	M6~M8	M6~M8	M8~M10	M10
Torque adjustment range (※1)		5~18N・m	7~20N・m	10~30N・m	15~35N・m	30~50N・m	40~60N・m
Weight	incl. battery pack	1.4kg	1.4kg	1.5kg	1.5kg	1.6kg	1.65kg
	excl. battery pack	1.0kg	1.0kg	1.1kg	1.1kg	1.2kg	1.25kg
Free speed setting range		HIGH : 1500~4800rpm		HIGH : 2000~4800rpm			
		MIDDLE : 1500~3000rpm		MIDDLE : 1500~3000rpm			
		LOW : 1200~1500rpm		LOW : 1200~1500rpm			
Total Length		161mm	161mm	166mm	166mm	173mm	173mm
Total Height including battery pack		248mm	248mm	248mm	248mm	248mm	248mm
Spindle Offset		29.5mm	29.5mm	29.5mm	29.5mm	29.5mm	29.5mm
Sq. Drive/Bit size		Hex6.35	9.5mm	Hex6.35	9.5mm	9.5mm	9.5mm
Tightening Bolt No./min ※2		10pcs./min.	10pcs./min.	8pcs./min.	8pcs./min.	6pcs./min.	5pcs./min.
Tightening No./charge ※2		1300pcs./charge	1300pcs./charge	800pcs./charge	800pcs./charge	700pcs./charge	650pcs./charge
Noise <EN62841-2-2> Standard	Sound pressure level L _{PA}	67dB	67dB	68dB	68dB	69dB	70dB
	Uncertainty K _{PA}	3dB	3dB	3dB	3dB	3dB	3dB
Total values for three measured axes of vibration <EN62841-2-2 Standard> ※3		<2.5m/s ²	<2.5m/s ²	<2.5m/s ²	<2.5m/s ²	<2.5m/s ²	<2.5m/s ²
Ambient operating temperature		0~40°C					
Ambient operating humidity		35~80%RH((no condensation))					

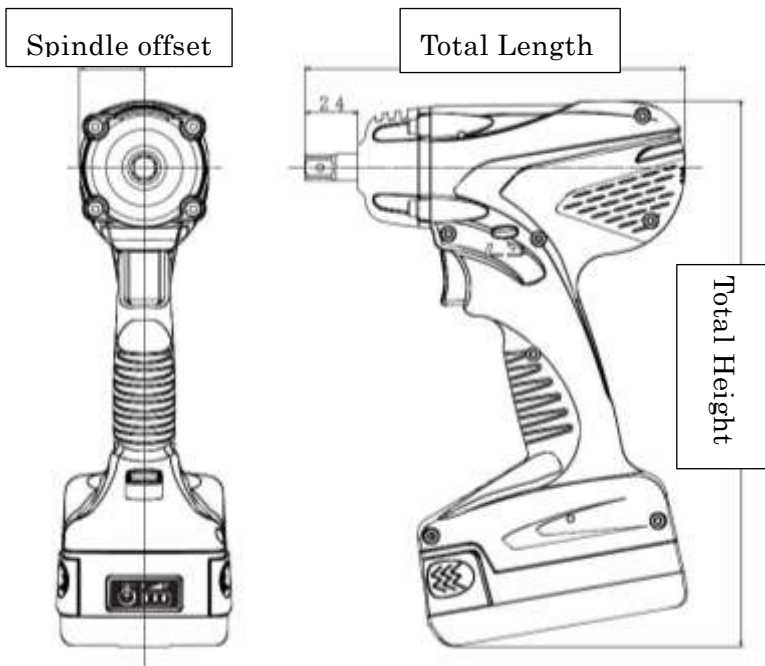

- ※1 Max. value of each adjustment range is at hard joint
- ※2 The value when our work is tightened at tightening time of 0.5s and ambient temperature of 30 °C. It varies with the condition of the work or operating environment and should be used as a guide.
- ※3 Triaxial combined vibration value was measured according to the standard EN 62841-2-2 and no value is measured in actual field. This value should be used as a reference for the management of daily exposure to vibration. Daily exposure to vibration A (8) is exposure to vibration per day, and it can be calculated from the following formula with triaxial combined vibration value “a” [m/s²] of the tool and the period of exposure to vibration per day “T” [h].

$$\text{Exposure to vibration per day } A(8) = a \times \sqrt{\frac{T}{8}} \quad [\text{m/s}^2]$$

- Battery Pack

Model	BPL-1820
Nominal voltage	18V
Rated capacity	2.0Ah
External dimensions	(W) 76mm× (L) 119mm× (H) 45mm
Weight	0.41kg
Ambient operating temperature	0~40°C

- Battery Charger

Model	BC0075G
Rated input voltage	AC100~240V±10% 50/60Hz
Rated charging current	2A ※1
External dimensions	(W) 200mm× (L) 130mm× (H) 84mm
Weight	0.84kg
Recharge time	80% charged : 60 min Fully charged : 70 min
Ambient operating temperature	0~40°C

※1 : At quick recharge

- Programing Console

Model	PC-1
External dimensions	(W) 100mm× (H) 185mm× (D) 24mm
Weight	0.3kg

- Special Cable

Model	CC-1
Total Length	2.3m
Weight	0.2kg

■ 5. Each part description

• TOOLS



① Main Shaft	Rotates as the trigger is pulled.
② Throttle lever	Lever to start or stop the rotation of the main shaft of the tool.
③ Reverse lever	Lever to switch the rotational direction (right/left) of the main shaft.
④ Cooling fan (built-in)	Fan to cool motor section and pulse unit.
⑤ Exhaust outlet of cooling fan	Exhaust outlet of cooling fan. Also used as insertion opening for torque adjustment pin.
⑥ LED Lamp	LED to inform the worker of tightening judgement, alarm and error.
⑦ Cable connecting port	This is the port to connect the setting device. When connecting, open the shutter. When not connecting, close the shutter until it is locked.
⑧ Battery pack (For -Z models, to be sold separately.)	Detachable battery pack for driving the tool.
⑨ Identification Mark	YZ-TH series are yellow.
⑩ Push Button	Gently push the button by TF pin for pairing. ※ When pushing at the error occurrence, detailed information displays on LED lamp.

● Explanation of Symbol mark



: Before use, read this Instruction Manual carefully and use the product properly after fully understanding the Manual.

▪ **Battery Pack** (For -Z models, to be sold separately.)



① Terminal part	Terminal for connection with the tool
② Ventilation opening	Air intake for cooling the inside of the battery pack during charging
③ Battery level indicator lamp	When PUSH button is pressed, the LED(s) light up and indicate the level of the battery pack. 《Guide for battery level》 3 LEDs lighting: Not less than 75% 2 LEDs lighting: 30 to 75% 1 LED lighting: 5 to 30% (charge the battery pack as soon as possible)
④ Anti-short-circuit cap	Cap to prevent from short-circuit of terminal parts
⑤ Release button	Button to release the battery pack from the tool

▪ **Battery Charger** (to be sold separately)



① Indicator lamp	LED lamp indicating the charging level
② Ventilation openings	Openings for cooling the battery pack.
③ Power supply cord	Dedicated power supply cord for battery charger

• **Programing Console PC-1 (To be Sold Separately)**

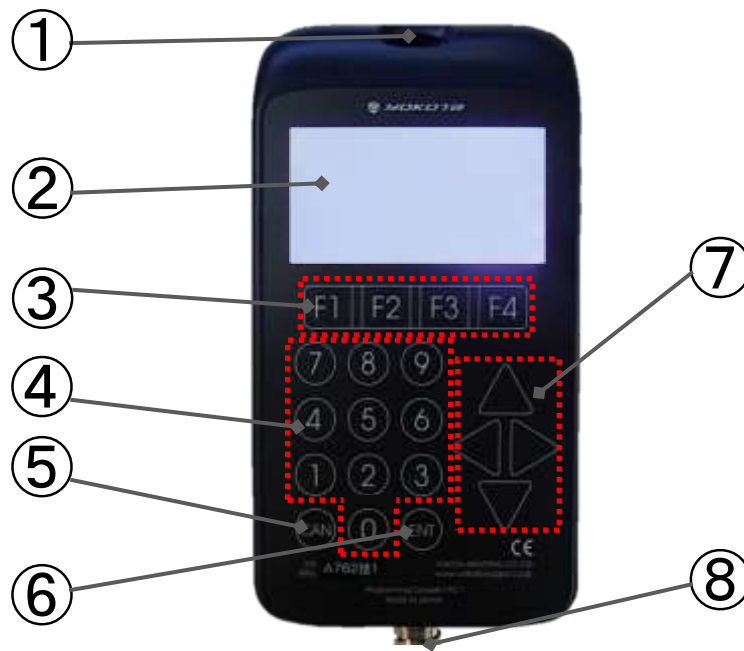

① Mounting hole	
② Display screen	Displays tightening result, setting item and set value
③ Function key	Switching of tightening screen, setting screen and or of display screen
④ Numeric key	Enter the set value
⑤ CAN key	Return to the previous screen
⑥ ENT key	Determine items and input value
⑦ Up, down, left and right key	Move the selection of setting items up and down
⑧ PRC05 connector	Connector for connecting cable

• **Special Cable CC-1 (To be Sold Separately)**



① PRC05 connector	Connector for connecting with programing console PC-1
② YZ-TH Connector	Connector for connecting with YZ-TH

■ 6. Preparation before use





 Before use, read, especially 「●Installation, Environment」 of Chapter 1 「■Safety Care」 carefully and use the product properly after fully understanding the Manual.

Since the battery pack you purchased is not fully charged, fully charge it before use.

6.1. Method of charging

- ① Connect the battery charger to the power supply cord, and insert the power plug into the receptacle. The LED of the charger is still off.
- ② Insert the battery pack into the battery charger.
Slide the battery pack to the end along with the insertion slot of the battery charger.
When it is correctly installed, the LED lights in red and the charging starts.
※ Depending on the temperature of battery pack, the cooling fan activates or stops.
While charging, operation of the cooling fan varies but it is not the malfunction.
When the charging is completed (fully charged), the LED lights in green.
- ③ Remove the battery pack from the battery charger
- ④ Remove the power plug of the battery charger from the receptacle.

6.2. Lightening pattern of indicator lamp of the battery charger

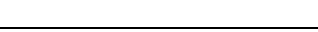
LED Display Condition LED		Lighting Condition	Charging Condition
Color			
Off		Off	Condition of plugging in
Red		Lighting	Charge in process
Green		Blinking	Practical charge (80%) completed
Green		Lighting	Charge completed
Orange		Blinking	Charge standing-by (Temperature of battery Pack is high/low.)
Red		Blinking	Charge impossible (Abnormality etc. of battery pack)

6.3. Installation of the battery pack

Slide the battery pack along the insertion slot of the tool to the end and make sure that it does not come off (it clicks when the battery pack is slid to the end).

6.4. Removal of the battery pack

While pressing the eject buttons on both sides of the battery pack, slide it to your side

■ 7. Pairing

The product can be possible to communicate the rundown data (tightening OK only) to the receiver for pokayoke TW-800R series (hereinafter called “receiver”) made by Herutu Electronics Corporation.

To make the communication effective, the pairing (initial connecting setting) between the tool and receiver, is necessary.

7.1. Pairing Procedure

After putting on the power switch of receiver, proceed the pairing with the following procedure.

For the operational details of the receiver, refer to the instruction manual issued by Herutu Electronics Corporation, attached with the receiver.

- ① Install the battery pack to the tool.
- ② Activate the tool by pulling the throttle lever once.

Be careful, since the main shaft of the tool rotates at the same time when the throttle lever is pulled.

- ③ By pressing the light switch for pairing, at the same time put on the power switch.

(Refer to the below)

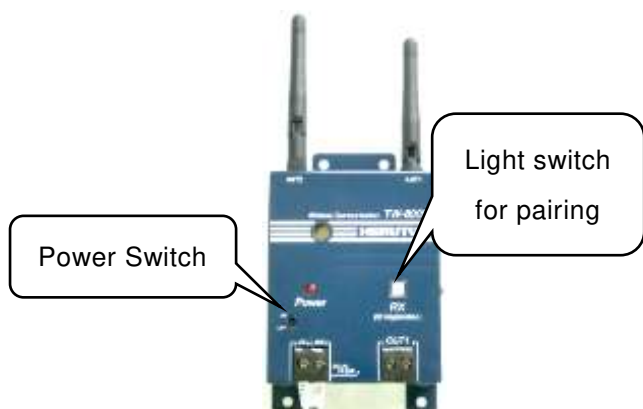

- It turns to be in the pairing mode for 10 seconds and the light switch for pairing is blinking.
- After a lapse of 10 seconds from the pairing mode, the pairing mode automatically finishes and the light switch for pairing stops blinking to put out the light.

If the pairing is not successfully done during that period, put off the power switch of the receiver again and re-start the pairing operation

- ④ While the light switch for pairing of the receiver is blinking, do the pairing by pressing the push button located on the backward of the tool with the flat bottom of TF pin 2x90. (Refer to the below.)





- At the same time when it is pressed, white LED on the back of the tool lights. Hold pressing until the buzzer beeps.
- At the same time when the long beep starts, the white LED goes off and then, remove the TF pin from the push button. “



- **When pressing the push button for a long time for pairing, slowly remove the TF pin from the push button right after the white LED goes off and the long beep starts. Keep pressing can not enable the pairing.**
- **Do not remove the battery pack from the tool, during the pairing.**

⑤ When the pairing is successfully done, the light switch for pairing of receiver goes off and on the tool side, the blue LED lights for 0.5 second together with buzzer beep sound.

When the pairing is failed, on the tool side the purple LED lights for 0.5 second together with intermittent buzzer beep sound. Do the pairing procedure once again from the beginning.

Condition	Buzzer sound pattern	LED lighting pattern
When pairing is successful	The buzzer beeps.	Blue lighting for 0.5 sec. 
When pairing is failed	The buzzer beeps intermittently.	Purple lighting for 0.5 sec. 

⑥ After the pairing is successfully done, put off the power switch of the receiver once without fail and put it on again. By doing so, the communication can be possible with the tool paired.



Even if the pairing is successfully done, the communication with the tool can not be possible, unless the power switch of the receiver is turned OFF/ON.

⑦ Others

- Even if the battery pack is removed and installed again after the completion of pairing, the pairing status is maintained. Likewise, even if the power switch of the receiver is turned OFF/ON, the pairing status is maintained.
- To release the pairing of the tool, do the pairing procedure at the status when the receiver is not in the pairing mode. After it turns out to be the failure of the pairing (purple LED lighting), the pairing will be released.



■ 8. Use

 Before use, read, especially 「●Operation, Driving」 of Chapter 1 「■Safety Care」 carefully and use the product properly after fully understanding the Manual.

8.1. Operation Mode

Stand alone	
Using YZ-TH alone	
Stand-by mode	This is the mode before pulling the throttle lever after installing the battery pack or after 15 minutes from the last pull of the throttle lever. Cooling fan and LED would be turned off.
Operation mode	When pulling the throttle lever at stand-by condition, it turns into operation mode and the main shaft rotates, activating the cooling fan. During the operation mode, LED lamp lights and the buzzer sounds at tightening judgement. At the occurrence of alarm or error, LED lamp lights or blinks. After 15 minutes from the last pull of the throttle lever, it goes into a Stand-by mode.
Operation connecting with setting device	
Using YZ-TH connecting with setting device	
Setting Mode	When pulling the throttle lever after connecting the setting device and then, installing the battery pack, setting mode starts. The cooling fan and LED lamp do not activate. This mode can set tightening parameter, check the rundown results, and run into test mode. *Note: The tool does not run even when pulling the throttle lever at the setting mode
Test Mode	By selecting the test mode from the setting mode, test mode starts. At test mode, the main shaft rotates when pulling the throttle lever and tightening can be possible. The tightening results display on the setting device.

8. 2. Functions of throttle lever and reverse lever

<p>Throttle lever</p> <p>After inserting the battery pack and then pulling the throttle lever, the main shaft rotates.</p> <p>When pulling the throttle lever lightly, the rotation speed sets to be [low] and when pulling it more, it sets to be [middle]. After releasing the throttle lever, rotational operation stops.</p>	
<p>Reverse lever</p> <p>It switches the rotational direction of the main shaft. When pressing its R-side and pulling the throttle lever, it rotates right and when its L-side, it does left.</p> <p>※*While the main shaft rotates, do not operate the reverse lever.</p>	 <p>Press R side : Right Press L side : Left</p>

8. 3. Tightening Judgement (Correlation with judgement, value and pulses)

- ① After tightening, the tool judges whether the tightening results (the value and pulses) are within the setting range
- ② If the tightening results (value and pulses) are within the setting range, the tool judges OK.
- ③ If the tightening results (value and pulses) are not within the setting range, the tool judges NG.
- ④ Tightening NG details
 - ・ Value NG (less than cut value / more than cut value / value before average exceeded max value)
 - ・ Pulse NG (less than min pulse / more than max pulse / slow err)
- ⑤ Slow : Pulses exceed slow error pulses (70 fixed) including those less than start value

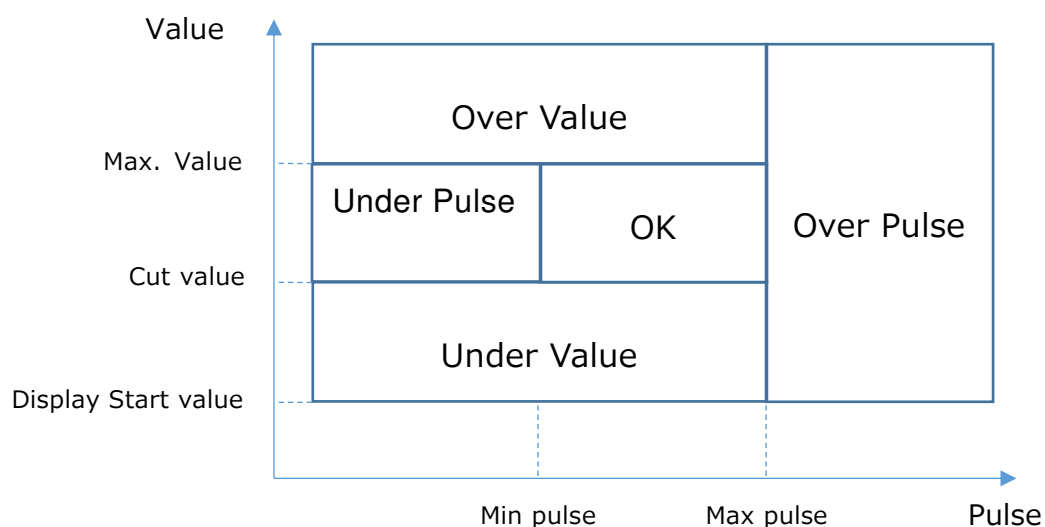

※Value : A guide value at which the tool will shutoff once it reaches during rundown

8.4. Method of adjustment of output

8.4.1. Adjusting the output by rotation speed of the motor

Output value is adjusted by changing the high speed setting of the motor.

If the high speed setting of the motor is increased, the output of the tool becomes bigger, and if it is decreased, the output becomes smaller.

The setting of rotation speed is saved in the YZ-TH and it is to be changed by the setting device (PC-1 etc.).

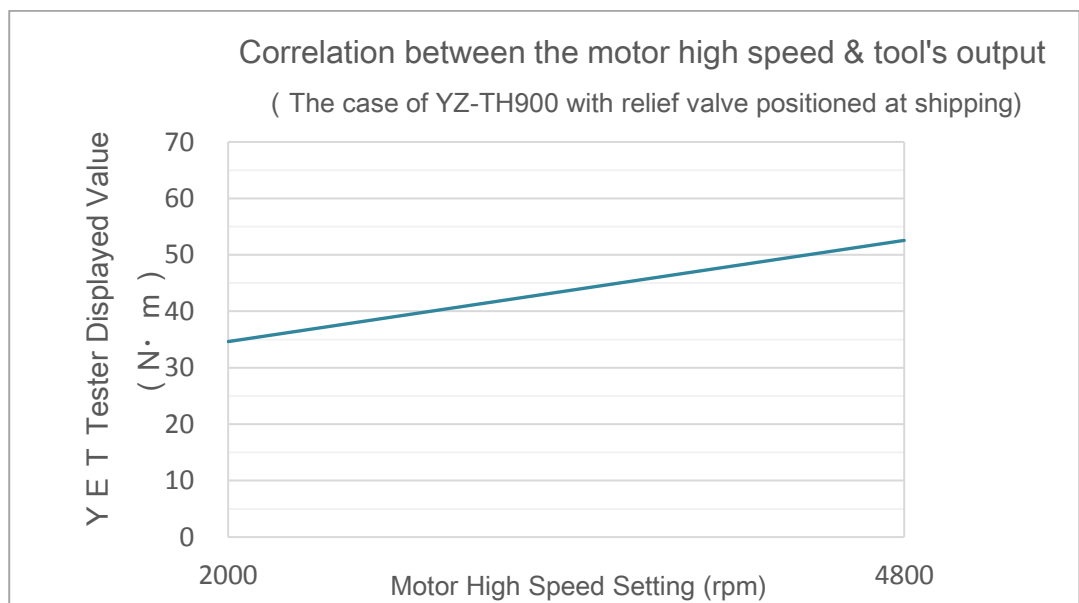
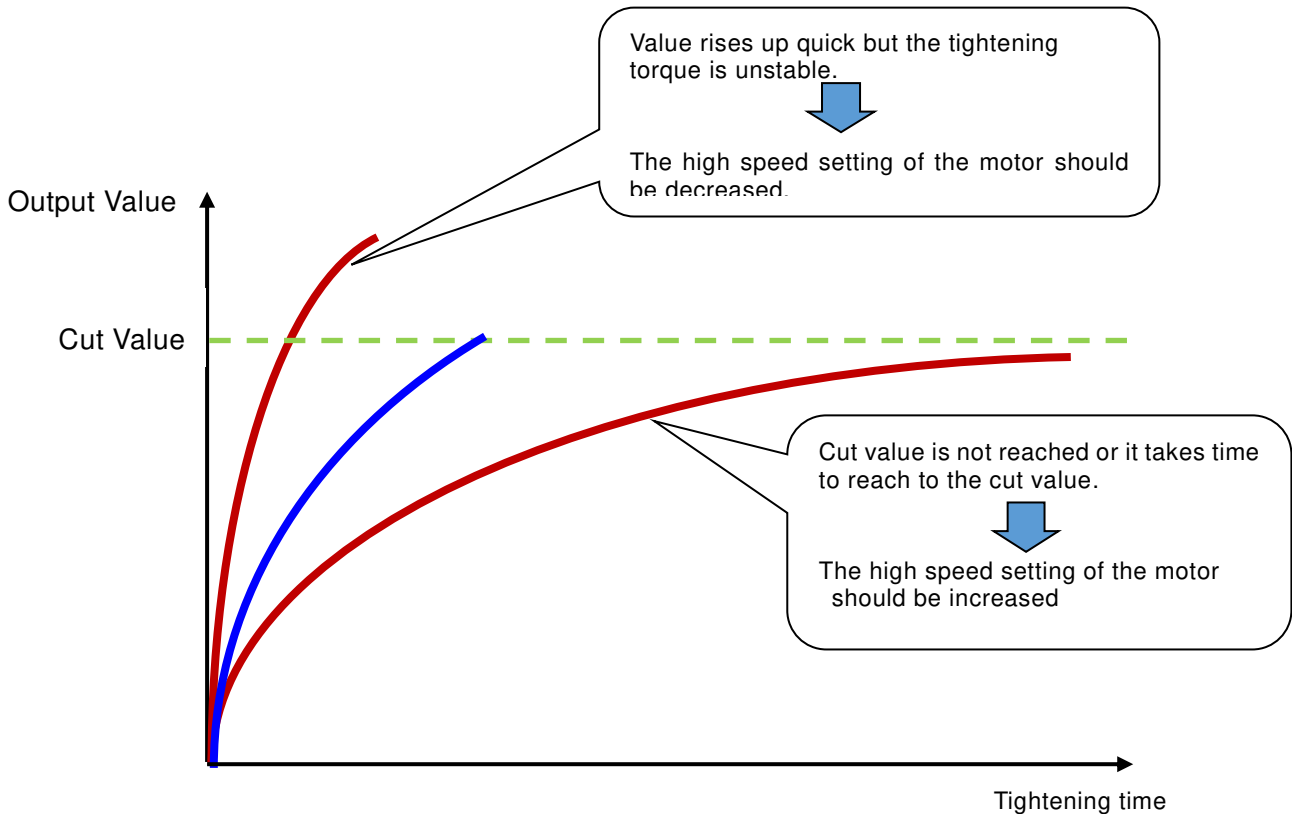

※The above is one example of the tester displayed value of YZ-TH900 measured with our tester YET-1001C.

8.4.2. Adjusting the output by relief valve

Tool's output can be adjusted by changing the relief valve position.

① Positioning of the relief valve adjusting hole

Detach the battery pack, and rotate the main shaft until the relief valve adjusting hole is visible.

② Adjusting the relief valve

Adjust the valve by using the standard accessory TF pin, holding the main shaft not to rotate.

Turn left to tighten (MAX output), and turn right to loosen (MIN output)

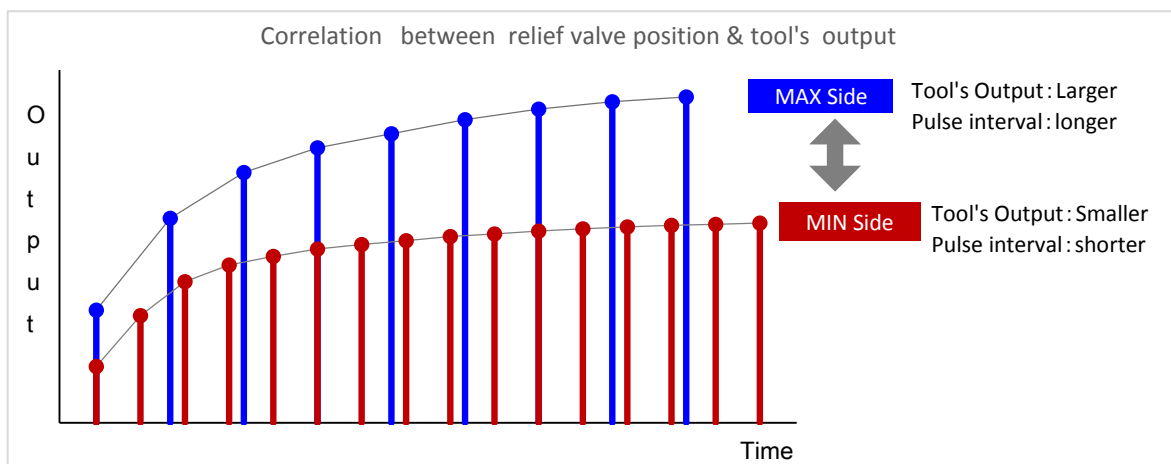
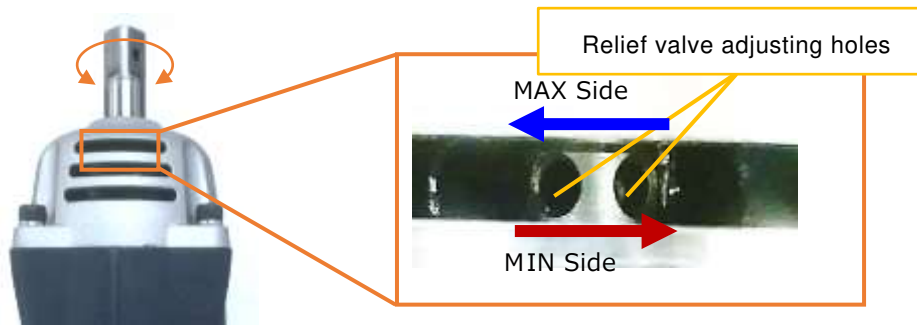

⚠ Do not use the tool with relief valve fully loosened(MIN) or tightened(MAX)

Rotate at least 60 degrees loosened from fully tightened (MAX) or 60 degrees tightened from fully loosened (MIN).

8.5. Operation by setting device

By connecting the setting device (PC-1 etc.) to the YZ-TH, it is in setting mode and main menu screen displays.

8.5.1. Start Screen

After connecting the setting device (PC-1 etc.), it displays the below screen, and then moves to the main menu screen. The main menu screen shows YZ-TH model.

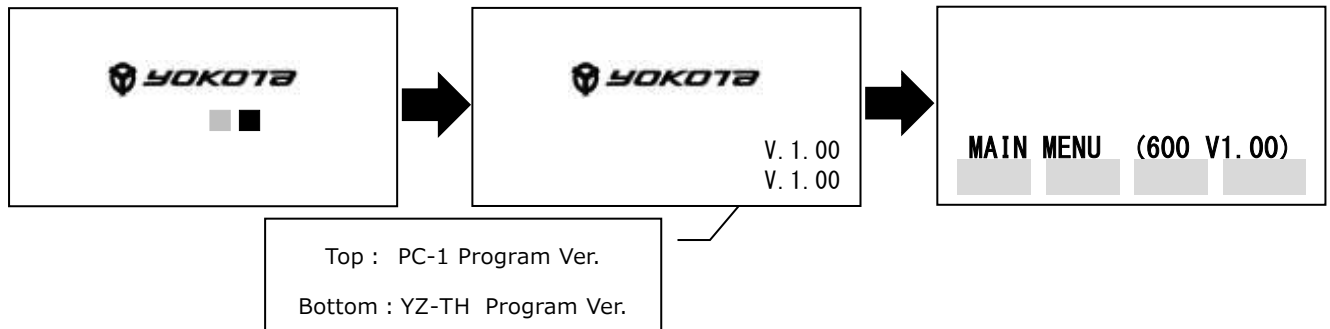

8.5.2. .Parameter Setting

Press enter on the PARAMETER SETTING to go to the parameter setting screen.

Select the setting value by up & down key and by pressing enter [ENT] key, input/change each parameter setting value.

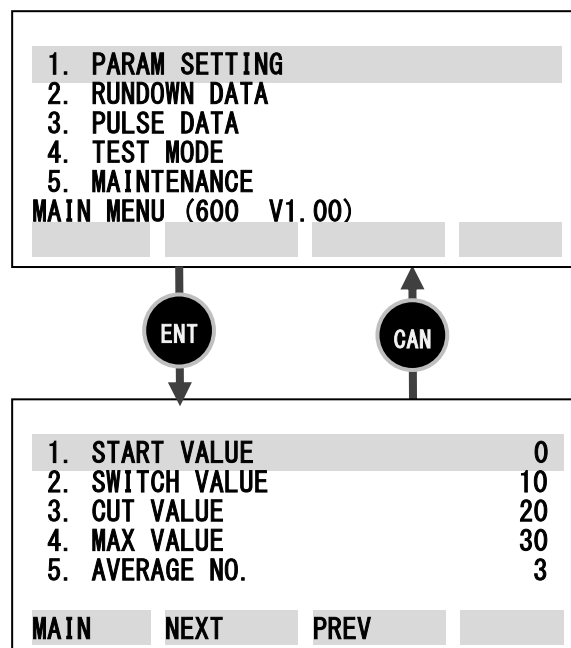

- Entering the value: Use the arrow keys to select digit and enter the numbers by numeric key..
- Setting value switching (ON⇔OFF, etc.): Press up & down key to change

Press [ENT] to set the input value

Press [CAN] to cancel the input value

If the setting item is more than one page, press [NEXT] key to move to the next page and press [PREV]to move back to the previous page.

By pressing [MAIN] key or [CAN] key, it moves back to top MAIN MENU screen.

8.5.3. Reference of rundown result history

Select RUNDOWN DATA by up & down key and press enter key to go to the RUNDOWN DATA screen. If the rundown result is more than one page, press [NEXT] key to move to the next page and press [PREV] to move back to the previous page.

The latest 50 rundown data is stored.

By pressing [MAIN] key or [CAN] key, it moves back to top MAIN MENU screen.

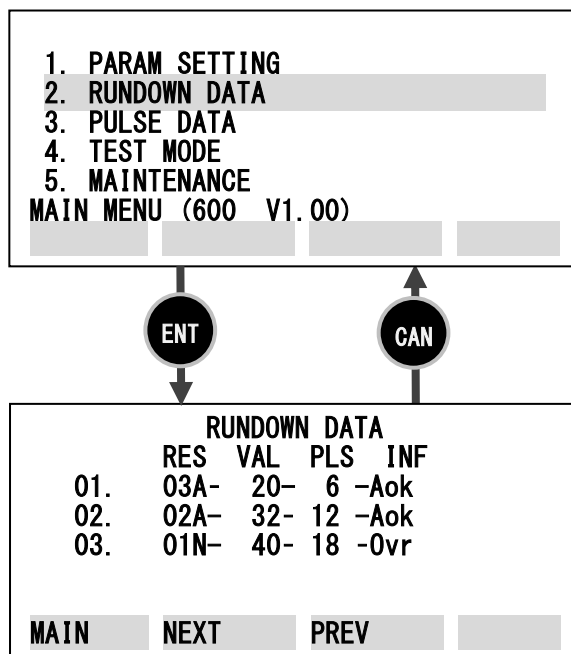

Rundown result screen

Items	Contents
Rundown Sequence	Rundown sequence no. (1 ~99)
Total Judgement	Rundown judgement result, OK or NG A : Tightening OK N : Tightening NG
Output Value	Output value at rundown judgement
Pulse number	Pulse number at rundown judgement
Rundown result details	Rundown judgement result details Aok : OK Udr : Under Value Ovr : Over Value N55 : Under Pulse N57 : Over Pulse Slw : Pulses exceed preset slow error pulses (70 fixed) including those less than display start value

8. 5. 4. Reference of pulse data history

Select PULSE DATA by up & down key and press enter key to go to pulse data screen.

Select Pulse Data to be referenced by up & down key and press enter key.

Pulse data for the latest 5 rundowns can be stored. If the pulse data is more than one page, press

[NEXT] key to move to the next page and press [PREV] to move back to the previous page.

By pressing [MAIN] key, it moves back to top MAIN MENU screen or by pressing [CAN] key,

to move back to PULSE DATA/ MAIN MENU screen.

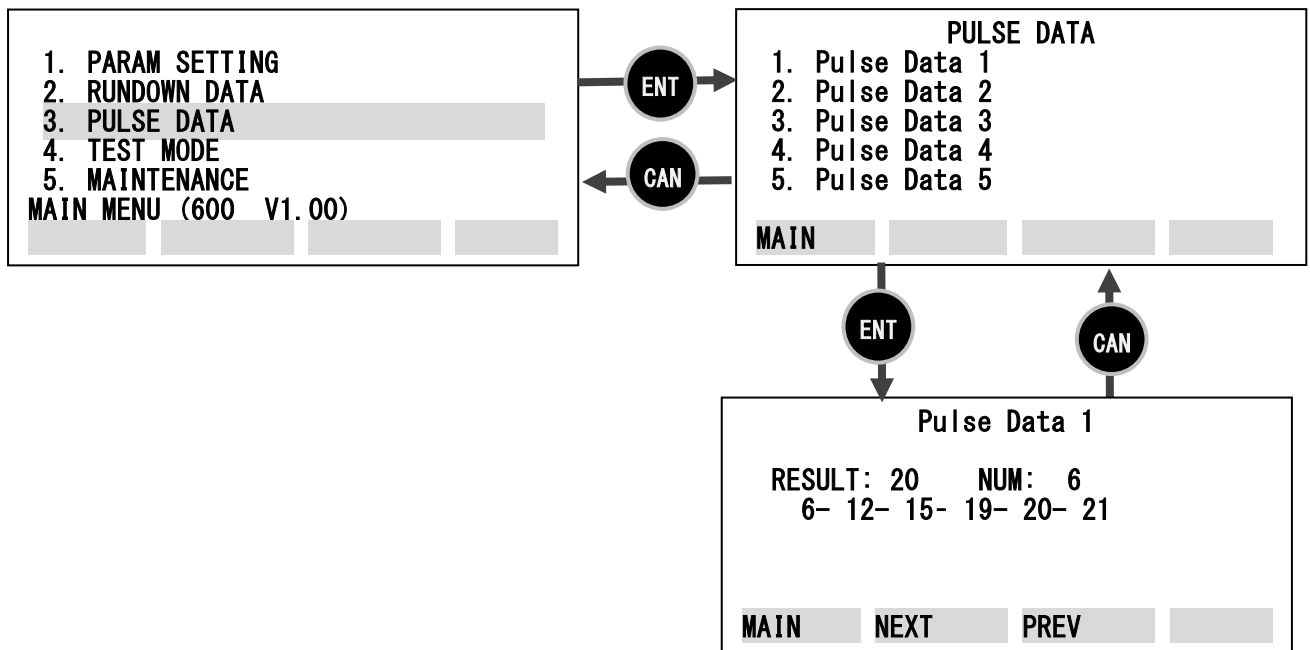

Pulse data

Items	Contents
Output Value	Result value at rundown judgement
Data Number	Number of pulse data
Value 1	Value per pulse
Value 2	Same as above
~	Same as above

※Maximum no. (N) from value 1 to value N is 70.

8.5.5. Test Mode

Select TEST MODE by up & down key and press enter key to go to test mode screen.

By pressing [MAIN] key or [CAN] key, test mode finishes and it moves back to top MAIN MENU screen.

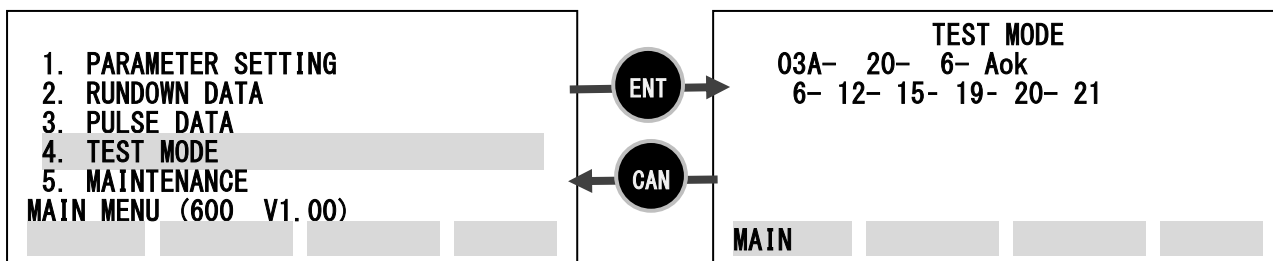

The test mode can enable the tool to rotate the main shaft after pulling the throttle lever as the usual rundown mode, and to tighten confirming the result after rundown judgement on the test mode screen. It is used for parameter setting and output adjustment.

Test mode screen can display 50 pulses as the pulse data. To see more than 51 pulses, escape from test mode once and confirm on the reference of the pulse data history screen explained on 8.5.4.



This is the operation by connecting with the setting device. Be careful of the cable entanglement or the excessive load on the cable connecting port.

8.5.6. Maintenance

Select MAINTENANCE by up & down key and press enter key to go to maintenance screen.

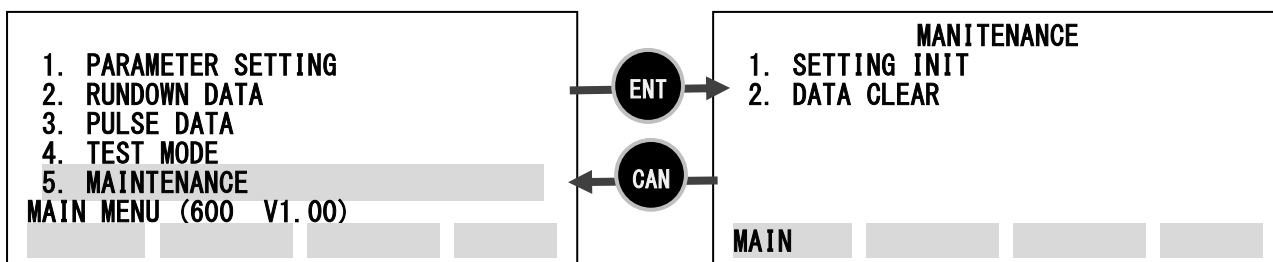

On the MAINTENANCE screen, select each item by up & down key and press enter key to conduct each function.

By pressing [MAIN] key or [CAN] key, it moves back to top MAIN MENU screen.

SETTING INIT : Initializing the setting parameter to the default value.

DATA CLEAR : Deleting all stored rundown data including the rundown results and pulse data.

8.6. Settings

Setting the parameter for YZ-TH by connecting the setting device.

Display Start Value START VALUE

Set contents	Selection Range	Default
Setting the display start value. The value to be as follows: Upper limit value \geq Cut value \geq Start value	10~150	10

Speed Shift Value from Mid to High SWITCH VALUE

Set contents	Selection Range	Default
Set the value to switch from motor mid-speed to motor high speed. The value must be, Switch value \geq Start value	10~150	10

Cut Value CUT VALUE

Set contents	Selection Range	Default
Set target value. Set the value to be as follows: Upper limit value \geq Cut value \geq Start value.	20~150	20

Upper Limit Value MAX VALUE

Set contents	Selection Range	Default
Set Upper Limit Value. The value to be as follows: Upper limit value \geq Cut value \geq Start value.	20~150	20

Motor Low Speed LOW SPEED

Set contents	Selection Range	Default
Set the motor low speed	1200~1500 (rpm)	1200

Motor Middle Speed MIDDLE SPEED

Set contents	Selection Range	Default
Set the motor middle speed	1500~3000 (rpm)	2000

Motor High Speed HIGH SPEED

Set contents	Selection Range	Default
Set the motor high speed	1500~4800 (rpm) * YZ-TH600 2000~4800 (rpm) * Others	3000

<i>Average Number AVERAGE NUM.</i>		
Set contents	Selection Range	Default
Set average number	2~3	3
<i>Upper Limit Pulses MAX PULS</i>		
Set contents	Selection Range	Default
Set the upper limit number of pulses	1~70	30
<i>Lower Limit Pulses MIN PULS</i>		
Set contents	Selection Range	Default
Set the lower limit number of pulses.	1~70	2

■ **9. Performance Inspection Mode**

Use this mode to confirm the performance of the tool itself and so on.

9. 1. **Attach the battery pack.**

9. 2. **While pushing the Push Button on the back of the tool, pull the throttle lever and release.**

Pushing the push button on the back of the tool, by TF pin 2x90.



9. 3. **Release the Push Button of the tool**

If the LED starts blinking in white, it indicates that the tool is in inspection mode

9. 4. **Change the motor speed**

In this performance inspection mode, the motor speed can be changed. (At the start of the performance inspection mode, the speed is 4800rpm.)

By pushing the Push Button, it toggles the speed between 4800rpm and 2000rpm



※ In the performance inspection mode, the tool does not shut off.

Any change of the parameter setting is not possible. Rundown result, history including the pulse data etc., would not be stored at all.

When disabling the performance inspection mode, remove the battery to turn it off



■ 10. Buzzer Sounds and LED lighting patterns

10.1. Tightening result















Condition	Buzzer sound pattern	LED lighting pattern
Tightening OK	Short beep	Lighting in green & OFF until the following conditions are met: 10 seconds elapsed, next buzzer sound, operation of the throttle lever. 
Tightening NG (Value Over, Pulse Under Value over before average)	Beep 6 times	Blinking red & purple repeats until the following conditions are met. 10 seconds elapsed, next buzzer sound, operation of the throttle lever. 
Tightening NG (Value Under, Pulse Over, Slow Error)	Beep 6 times	Lighting in red & OFF until the following conditions are met: 10 seconds elapsed, next buzzer sound, operation of the throttle lever. 

10.2. Communication status display



LED lighting patterns at the operation of the tool are same as those of YZ-T (without wireless specification). However, owing to the built-in wireless module, the following LED lighting patterns corresponding to the communication status with the receiver at tightening OK, are added.

Condition	Buzzer sound pattern	LED lighting pattern
Tightening OK but the receiver is in the busy status.	Short beep	Below (blinking in white & green) pattern repeats until the following conditions are met. 10 seconds elapsed, operation of the throttle lever 
Tightening OK but in the status of not receiving the reply from the receiver.	Short beep	Below (blinking in yellow & green) pattern repeats until the following conditions are met. 10 seconds elapsed, operation of the throttle lever 
Tightening OK but in the status of waiting for the reply from the wireless module.	Short beep	Blinking in green pattern repeats until the following conditions are met. 10 seconds elapsed, operation of the throttle lever, reply received. 

10.2. Warning・Alarm

	Condition	LED lighting pattern	
Warning・Alarm (Replace the battery or Restore after the elapse of the time)	Battery pack Remaining amount Warning	Repeating blue ON and OFF 	
	Motor over-heat alarm	Purple rapid flashing 	
	Driver over-heat alarm	Rapid flashing of purple and white 	
	Over-discharge of battery pack	Rapid flashing of purple and yellow 	
	Commutation offset alarm	Rapid flashing of purple and red 	
Maintenance is required	Degradation detection	Rapid flashing of red-yellow-purple 	
Error (Repair is required)	Commutation Error	Red rapid flashing (After red rapid flashing, press the push button to see the error message as explained in the right column. While pressing the push button, the lighting pattern as stated in the right column can be displayed.)	Repeating red - purple - green- off 
	Wire breakage of motor temperature sensor		Repeating red – yellow- green- off 
	Wire breakage of driver temperature sensor		Repeating red – green- purple- off 
	Over-voltage Error		Repeating red- purple- yellow- off 
	Over-current Error		Repeating red- purple- red- off 
	Motor lock Error		 Repeating red- greed- yellow- off 
	Abnormal pulse signal		Repeating red-green- blue- off 
	Memory Error	Repeating red-white-blue-off 	

■ 11. Accessories

Model	
Protector ※ 1	<p>YZ-TH600 : White YZ-TH800 : Blue YZ-TH900 : Black YZ-TH950 : Green</p> 
TF PIN 2×90 ※ 1	
Battery Pack BPL-1820 ※ 1 (not including -Z model)	

※ 1 : Use our designated parts as accessory.

■ 12. Maintenance and Inspection

 Regarding the maintenance and inspection of the product, read, especially 「●Maintenance, Inspection, and Repair」 of Chapter 1 「■Safety Care」 carefully and use the product properly after fully understanding the Manual.

■ 13. Caution on disposal

 Regarding the disposal of the product, read, especially 「●Disposal」 of Chapter 1 「■Safety Care」 carefully and use the product properly after fully understanding the Manual.

■ 14. Troubleshooting

Before asking repair, carry out the following checks. If the trouble cannot be solved by the following actions, or if any trouble other than below occurs, stop using the product immediately. After detaching the battery pack from the product, be sure to ask us or our authorized (designated) servicing factory via the distributor or sales agent you have purchased from.

Trouble	Probable cause	Action
The tool does not operate.	The motor is overheated.	Wait until the motor gets cool and the LED goes off.
	The battery pack is over-discharged.	The battery voltage falls below a certain level and protective function is active. Charge the battery pack. ※Be sure to charge the over-discharged battery pack to full level. If the charging level is not sufficient, the protective function may not be released.
	Low voltage error is outputted.	Replace the battery pack. Low voltage error may be outputted, when the battery pack with degraded performance owing to the deterioration, low temperature etc., is used. Normally, the over-discharge protection inside the battery pack is, in the first place, functioned and the low voltage error will not be outputted.
	The tool is in a setting mode.	In case that the tool is in the setting mode with the setting device (PC-1 etc.) connected, detach the battery pack and disconnect the setting device.
	Following error is outputted: <ul style="list-style-type: none"> • Commutation Error • Motor lock Error • Wire breakage error of motor temperature sensor • Wire breakage error of driver temperature sensor • Over-voltage Error • Over-current Error • Abnormal pulse signal • Memory Error 	Ask for the repair to us or our authorized (designated) service shop. ※In the usage at an extremely low temperature, wire breakage error of motor/driver temperature sensor and motor lock error may be outputted owing to the cause of low temperature. Confirm at the proper ambient temperature.
When releasing the throttle lever during no-load rotation, there is a stop sound from the motor.	It is the operating sound of the brake when stopping.	It is not a trouble. Continue to use as it is.
Overheat alarm frequently occurs.	The load on the tool is big.	Use the tool having proper tightening capability suitable for the object to be tightened.
	The cooling fan is broken down.	Ask for the repair to us or our authorized (designated) service shop.
The total number of tightened pieces is a little, while the battery pack is fully charged.	It is the end of life of the battery pack.	Replace the battery pack.
No lighting of Indicator lamp for the status of charging (red) of the battery charger	Dust adheres to the terminals of the battery charger and the battery pack.	Clean the terminals after unplugging the power source cord.

Stand-by lamp (orange) for the battery charger blinks	The temperature of the battery pack is high or low.	Charge the battery pack in a location at ambient temperature of 0 to 40°C. If it is being charged in such a location as 0 to 40°C, continue the charging. When the battery pack reaches at temperature suitable for charging, the charging is automatically started.
Error lamp (red) for the battery charger blinks	The battery pack breaks down or the end of life	Replace the battery pack.