



Wireless Unit for battery pulse tools

WU-1

Instruction Manual



Thank you for purchasing YOKOTA products.

Before use, please read this Instruction Manual carefully and use the product properly after fully understanding the Manual.

Please be sure to keep this Instruction Manual.

 **YOKOTA INDUSTRIAL CO., LTD**

Head Office/Factory 5-55 Nishiiwata 3-chome, Higashiosaka City, 578-0947 Osaka, Japan

TEL.: +81-6-6788-1381 FAX. +81-6-6781-4519

<http://www.yokota-kogyo.co.jp>

目 次

1. SAFETY CARE	3
2. GLOSSARY	8
3. SPECIFICATION.....	11
4. EACH PART DESCRIPTION.....	12
5. PAIRING	14
6. SETTING METHOD	16
7. SETTING ITEMS.....	19
8. JUDGEMENT OF TIGHTENING	29
9. ASSIGNMENT OF OUTPUT RELAY AND INPUT TERMINAL.....	31
10. MAINTENANCE AND INSPECTION.....	32
11. TROUBLESHOOTING	34
12. EXTERNAL VIEW	36

1. Safety Care



Warning

Please be sure to thoroughly read this Operation Manual and fully understand the instruction to use correctly, before installation, operation and inspection.

In this Instruction Manual, safety precautions prefix either of the following safety alert pictograms.

All are important items relating to safety and must be observed.



Warning··· Cases where mishandling induces a potentially hazardous situation, which, if not avoided, could result in a death or serious personal injury.



Caution··· Cases where mishandling induces a potentially hazardous situation, which, if not avoided, may result in minor or moderate personal injury or property damage.

※Notes: Even items described in “ Caution” may lead to serious consequences depending on circumstances.

- Retain this instruction Manual in a place where it is always available for anyone who needs to use it.
- In cases where you lost this Instruction Manual or the warning label affixed to the product or made it dirty, immediately contact us or your YOKOTA representative to obtain the Manual or the warning label, and then properly retain the Manual or replace the warning label.
- In cases where you transfer or rent this product, be sure to attach this Instruction Manual to it.
- Should you have any questions about the product you purchased or this Instruction Manual, please contact us or your YOKOTA representative.

■ Please use this product by connecting with the power supply supplied from "Electric work for the business" decided by the Article 38 of Electric Business Act. It is not possible to use it by connecting with "Electric work for general" (generally, commercial power source in the home, the shop, etc.).

1.1. Working Environment



Warning

- Ensure that the workplace is sufficiently light.
Working in a dark place may result in accident or injury.
- Do not operate the tool and charge the battery in explosive atmospheres, such as in the presence of flammable liquids, gases or dusts.
There is fear of fire.
- Keep anyone, particularly children, other than those involved in the work away from the work site.
Not doing so could induce a hazardous situation.
Otherwise, it may cause injury.

- Take drop preventive measures such as use of safety wire to work in high places. Also be careful for the falling-off accident, by confirming surely the safety of scaffolding.
- Do not install this product in a place likely to be exposed to water, direct sunlight, much dust, heat, oil, or moving parts of industrial equipment. Otherwise, it may cause fire, electric shock, or accident.

1.2. Electrical Safety



Warning

- This product is for the indoor exclusive use. Do not use it in rain, in a damp place and a wet place. Moreover, never use it in the place with the fear of the ignition and the explosion, because those are hazardous situation.
- Do not move by holding the power cord. Do not pull the cord to remove the plug from the socket-outlet. Avoid damage of cord due to stepping, entangling, or unreasonable force.
- Avoid pinching of power cord in the object to be tightened or surrounding facility in the tool operation and avoid the contact with rotating parts. The power cord may be damaged and it may results in accident.
- Use the battery charger at rated supply voltage (AC 100-240 V).
Do not use DC power supply, engine generator, or power transformer.
- Keep away from sources generating large electromagnetic noise, such as welder, DC brush motor.
- Be sure to use the provided power supply cord. Use of other power supply cord may cause malfunction, heat generation, or fire.
- Be sure to fully insert the power plug.
Failure to do so may result in electric shock or fire due to heat generation.
- If you do not use the product, unplug from the receptacle.
Wipe out dust or stain accumulated on the power plug or receptacle with a dry cloth.
Failure to do so may result in electric shock or fire.
- Do not insert or remove the power plug from the receptacle with wet hand.
Doing so may result in electric shock.
- Do not operate the switch with wet hand. Doing so may result in electric shock.

1.3. Human Safety



Warning

- Do not use the tool when you are tired or under influence of drugs, alcohol or medication.
A moment of inattention during the use of tool may result in serious personal injury.
- To protect yourself, wear personal protective equipment such as a hard hat(helmet), safety glasses, safety shoes.
And depending on work environment, wear earplugs, a dust mask etc.
- Working in unusual positions is dangerous. Hold the tool securely and carry out working in stable posture, preparing for accidental movement at the same time.

- Dress properly. When working, do not wear loose clothes or jewellery such as necklace. If your hairs are long, bundle them with rubber ring to avoid contact with the tool and wear a protective cover such as cap. Otherwise, it may cause injury.

1.4. Operation and Care



Warning

- To prevent bodily injury due to installation, e.g. in the event of earthquake, install the product firmly.
- Do not load on the top of the product. Doing so may result in injury due to drop.
- Install the product on non flammable material such as metal. Failure to do so may result in fire.
- Do not place flammables near the product. Failure to do so may result in fire.
- Install the product in a stable, less vibrating place capable of withstanding its weight, in consideration of the communication range with the tool used.
- Keep the antenna away from the wall. If it is near the wall, the effect of reflection from the wall may make the communication status worse. Keep it away from the wall as far as possible.
- Ask electrical work professionals to do wiring work. Failure to do so may result in electric shock or fire.
- Ensure correct and secure wiring.
- Avoid tangle or pinching of the power supply cord.
- Avoid the use by persons inexperienced for handling. Otherwise, it may result in injury and/or accident.
- Handle the power tool carefully. Abuse may cause accident and/or malfunction. Do not give impacts on it by throwing or dropping it.
- Do not place obstacles around the antenna. If any obstacle, such as metal in particular, exists, it may interfere with the transmission of radio wave.
- Do not set more than one wireless unit close to each other to pairing mode at the same time. Doing so may interfere with normal pairing of the tool.
- Do not hit the antenna. When a strong impact is applied on it, it may be damaged. In addition, breakage of wire may occur in it and disable the communication.
- Do not make the foreign object such as metal pieces, invaded to the product. There is fear of fire.
- NEVER make any modification. Doing so could result in accidents. In addition, never use the spare part other than the genuine one.
- Do not remove the parts. If you use as the mounted parts or screws removed, it may cause accident.
- If you feel uneasiness during the use, stop using the tool immediately and ask repair and inspection to YOKOTA or YOKOTA-authorized or designated servicing factory via the sales outlet or sales representative. If any accident or problem occurs due to the customer' s intended action such as disassembly of this product, we shall not be liable for such trouble.
- Do not supply the current exceeding the specified limit to input terminal. Doing so may result in fire.
- Store the product in the dry area, where children or untrained person can not get access to. It is dangerous for the untrained person to use it.

1.5. Maintenance, Inspection, and Repair



Warning

- Before maintenance, inspection, or replacement, unplug the power supply cord.
- Only qualified service personnel are allowed to do maintenance and repair. Repair or maintenance performed by non-qualified personnel may result in serious personal injury of the user.
- Wipe out the dirt on the housing of the tool by using the dry and soft cloth.
Do not use the chlorinated solvent, gasoline, thinners and the like, which work to melt the plastic.
- Ask repair and inspection to YOKOTA or YOKOTA-authorized or designated servicing factory via the sales outlet or sales representative where you bought the product. If any accident or problem occurs due to the customer's intended action such as disassembly of this product, we shall not be liable for such trouble.
- Do not open the cover of the unit, except that electric professional may remove and replace the built-in battery.
- Do not replace the built-in battery, unless you are not an electric professional. Doing so may result in injury or fire.
- Never charge the built-in battery. Doing so may heat the electrolyte in the battery and generate gas increasing the internal pressure. Then the battery may leak, heat, rupture, or ignite.
- Use the built-in battery for specified purpose only. Failure to do so may result in incompatibility of terminal configuration, etc. with the equipment, or mismatch of specification or performance.
It may result in leak, heat, rupture, or ignition of the battery.
- Do not put the built-in battery into fire, heat, disassemble, or modify it.
It may result in leak, heat, rupture, or ignition of the battery.
- Do not reverse the positive and negative terminals of the built-in battery.
Doing so may result in abnormal reaction due to short-circuit, and it may result in leak, heat, rupture, or ignition of the battery.
- If the electrolyte of the built-in battery gets in your eyes, do not pass your hand over your eyes, but flush the eyes with clean water well and seek medical attention.
- Do not bridge the positive and negative poles of the built-in battery with a wire. Do not carry or store the battery together with metal necklace or hair pin. Doing so may result in abnormal reaction due to short-circuit, and it may result in leak, heat, rupture, or ignition of the battery.
- In the event of leakage or unusual odor of the built-in battery, dispose of it as leaked electrolyte may corrode metal parts.
- Do not solder the built-in battery directly. Doing so may result in leak, heat, rupture, or ignition of the battery.
- Do not drop or throw the built-in battery to give a strong impact on it or deform it. Doing so may result in leak, heat, rupture, or ignition of the battery.



Caution

- Do not leave or store the built-in battery in a place exposed to strong direct sunlight or in a car under the scorching sun. Doing so may result in leak, heat, or rupture of the battery.
- Do not expose the built-in battery to water, etc. Doing so may result in heat generation of the battery.
- When disposing of this product, ask electric professional to remove the built-in battery.
- When disposing of the built-in battery, insulate the positive and negative poles with an insulating tape.
- Dispose of the main unit and the built-in battery in accordance with segregation methods, laws and regulations of the location of use.

2. Glossary

(1) Tightening Torque:

Output torque on completion of tightening.

(2) Tightening Pulses:

The number of pulses between the display start torque and tightening completion.

(3) Work:

A set of tightening points under the same tightening conditions.

(4) WORK Start:

The work selection input becomes start. With the group management function is on, when the work switching input is turned on, the remaining number of bolts is initialized and the group management starts.

(5) AUTO CLEAR:

A function used to automatically clear the count when the number of remaining tightening points reaches zero.

(6) END LS:

A function to judge group management with the LS set as END LS turned ON.

(7) COUNT NG:

Output when the tightening bolt number does not reach to the preset number at the input of END LS. After COUNT NG, when the tightening number reaches to the preset number, the output becomes OFF.

(8) WORK SEL:

Following work selection can be selected:

「BIT」 : Work can be selected by inputting work a ~ d.

「DATA」 : Work a ~ d can be selected by the input combination of input terminals WORK a and WORK b.

When selecting 「DATA」 , a ~ d Work can be selected by the input combination of input terminals WORK a and WORK b. And after the establishment of WORK c input, designated work can be changed.

	a	b	c	d
WORK a	x	o	x	o
WORK b	x	x	o	o
WORK c	o	o	o	o

o : Input x : No Input

(9) Sleep Time [SLEEP TIME] :

Time after throttle OFF till the power to the tool is turned off.

(10) START TRQ.:

Threshold torque to judge OK or NG.

No judgement of OK or NG is made if the torque is less than this threshold value.

- (11) SWITCH TRQ.:
Torque at which middle speed is switched to high speed.
- (12) MIN. TRQ.:
A lower limit value to make a judgment of OK/NOK.
- (13) CUT TRQ.:
A torque value at which motor is automatically stopped while tightening.
- (14) MAX TRQ.:
A upper limit value to make a judgment of OK/NOK.
- (15) FREERUNNING ANG:
Angle between the point where a main shaft starts to rotate and the display start torque.
- (16) FINAL ANG:
Angle between the display start torque and the tightening completion point.
- (17) FREERUNNING TIME:
Time to display start torque after main shaft starts rotation.
- (18) FINAL TIME:
Time to tightening completion from display start torque.
- (19) STOP ABORT TIME:
When the rotation of main shaft is stopped for more than this time, free running angle will be set to 0.
- (20) MOTOR LOW SPEED:
Rotation speed at no load when the tool throttle lever is set to the first step.
(at forward and reverse rotation)
- (21) MOTOR MID. SPEED:
Rotation speed at no load when the tool throttle lever is set to the 2nd stage. (when right rotation)
※In case of reverse rotation, setting of mid-speed is not valid (only low and high speed is valid).
- (22) MOTOR HIGH SPEED:
Rotating speed at no load when the Middle to High speed switching torque is achieved. (when right rotation)
Rotation speed at no load when the tool throttle lever is set to the 2nd stage. (when left rotation)
- (23) JUDGE TIME:
A set period of time to make a tightening judgment if there is no pulse during the period after the pulsing.
- (24) BOLT CO-EFFICIENT:
A coefficient number to recalculate the displayed torque of the Wireless Unit if the displayed torque greatly differs from actual torque.
- (25) AVERAGE NUM.:
The arithmetic average from the preset number of pulses to display torque.
- (26) SKIP NUM.:
The number of pulses in excess of the displayed start torque, which will be ignored.

(27) SLOW ERR NO.:

The number of pulses in excess of the preset number of pulses. Consequently, a slow error will result.

(28) COMPEMC NUM:

The number of pulses preset as compensation pulses, which will be performed after the display torque exceeds the cut torque, and the motor will be automatically stopped.

(29) BOLT NUMBER:

The number of tightening points of a single work with the group management function used.

(30) PASS:

The forced completion of work.

(31) RESET:

A function to cancel the output of each relay and initialize the remaining bolt number.

(32) SLOW2:

A tightening state where the number of pulses in excess of the number of SLOW ER pulses though the range of torque tightening is okay.

(33) RELAY TIME:

A function to specify the time to keep relay pulse output signal on.

(34) RUNDOWN:

Tightening data per one bolt.

(35) AD Val:

A mode in which a torque signal applied to the main shaft is displayed.

(36) A USB connector:

A USB thumb drive (USB flash storage) is connected to save tightening data and the set value. A USB thumb drive formatted by the FAT32 form with the capacity 8GB or less can be used. There is a possibility that the USB thumb drive cannot be used according to the usage condition of the USB memory or a type of the USB thumb drive. Moreover, as the data to be saved is going to saved under the same file name, please make sure to copy or save the existing file written in the USB thumb drive to another media. The USB thumb drive formatted by the NTFS or other form must be reformatted by the FAT32 form using a PC. In that case, all the data previously saved will be deleted. Therefore, please make sure to format the USB thumb drive after making a backup of the data to another media.

If USB memory is provided with special function such as write-protect, its operation may be limited or it cannot be used.

3. Specification

Model	WU-1
External dimension	54mm (W)×249 mm(H)×188 mm(D)
Weight	1Kg
Ambient operating temperature	0 – 45 °C
Ambient operating humidity	35 - 80 % RH (without condensation)
Power supply used	AC100-240 V±10% 50/60Hz
Power supply capacity	80 VA
I/O terminal block	8 points for input (DC 24V built-in power source used) 8 points for output (no-voltage contact signal) The length of the cable must be less than 10 m .
Specification of input terminal	Driving voltage: DC 24V±10% Driving current: 5 mA TYP.
Specification of output terminal	Maximum load: DC 30V 0.5 A (Minimum load: 5 V 1 mA)
Serial port	RS-232C D-sub 9P The length of the cable must be less than 10 m .
LAN	10BaseT/100BaseTX auto-detect Note) Attach a noise filter (accessory of LAN specification: sleeve ferrite clamp, GRFC-6 manufactured by Kitagawa Kogyo) on LAN cable (interconnecting cable with HUB, etc.), at the nearest point to the main unit (see the photo below). The length of the cable must be less than 30 m.
USB	A-female connector
Connector for DS-1	I2C female connector (5-pin) The length of the cable must be less than 10 m.
Connector for PC-1	I2C female connector (6-pin) The length of the cable must be less than 10 m.
Standard accessory	AC adaptor of 2 m, Power supply cord of 1.5m, Stand, Noise filter (sleeve ferrite clamp GRFC-6)
Special accessory	Rubber feet (C-30-RK-15-EP-UL-Black) Fixing screw for rubber feet (cross-recessed head round machine screw M3 × 6) Coin type lithium battery (CR2032)



Installation of noise filter

4. Each part description



① Power LED	When the power is ON, LED (green) lights up.
② TOOL LED (TOOL 1-4)	Paired TOOL number lights up in green. When the tightening is OK, it lights up in green. If not OK, it lights up in red.
③ USB connector	Connector for connection of USB memory, to save tightening data, setting data, etc.
④ Pairing button	Button for pairing with the tool.
⑤ RS-232C connector	Port for communication with external device. Use RS-232C cable (9P male: straight) for communication.
⑥ Ethernet connector	Connector for Ethernet connection.
⑦ I/O terminal block	Terminal block for input and output. It has 8 points for input and output respectively, and 24 V output. The terminal block is removable, but keep checking the terminal No. on the terminal block when attaching, and take great care to avoid misconnection.
⑧ Connector for PC-1	Connector for the cable for PC-1.
⑨ Connector for DS-1	Connector for the cable for DS-1.
⑩ Power switch	Switch to turn ON/OFF the power to the wireless unit. If the unit is not used, turn the switch OFF.
⑪ AC adapter terminal	Terminal for connection of AC adapter.
⑫ Period of replacement of battery	Period of replacement of the built-in battery (coin type lithium battery (CR2032)).

● Descriptions of symbols

 **WARNING:** Indicating that mishandling may result in death or serious injury of the user.



: Be sure to read this Manual before use and use the product correctly after you fully understand its contents.



: POWER



: SERIAL PORT



: USB PORT



: LAN



: DS-1 Connector



: PC-1 Connector



: POWER ON



: POWER OFF

5. Pairing

To operate the tool, pairing with the wireless unit (initial connecting action) is required.

After turning on the wireless unit, carry out pairing according to the following steps.

5.1. **Install the battery pack to the tool.**

5.2. **Pull the throttle lever.**

It beeps and the tool is activated.

5.3. **Press the pairing button of the wireless unit for a while.**

Press the button until the LED of TOOL1 of the wireless unit lights up in red.

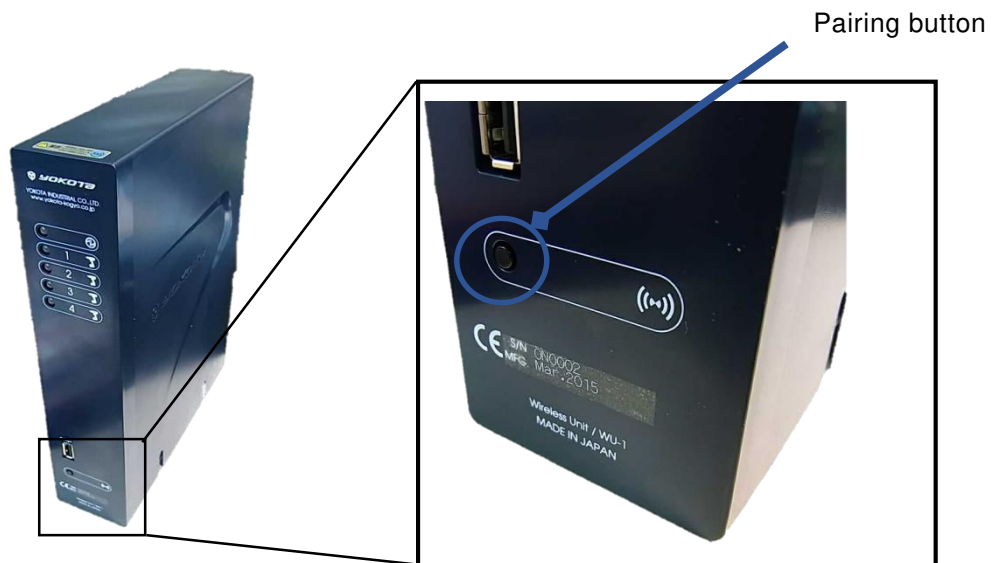

5.4. **Press the pairing button of the wireless unit for a short period and select the TOOL number to be paired.**

Every time you press the button for a short period, the lighting of LED moves.

5.5. **Press the pairing button of the wireless unit for a while.**

Press the button until the LED blinks fast.

5.6. Press the pairing button of the tool.

Press the button with the flat face of TF pin 2 x 90 until it beeps and the LED of the tool blinks fast in yellow.



***Do not continue to press the pairing button after the buzzer beep and fast blinking of the LED.**

***After the battery pack is installed and the throttle lever is pulled, make sure that the LED blinks in blue or yellow. Then press the pairing button.**

Regarding the blinking of the LED, if the pairing is done, it blinks in blue (only one blinking). If the pairing is not done, it blinks in yellow (repeated blinking).

Figure 1 Pressing-down timing of pairing button (After attaching the battery pack.)

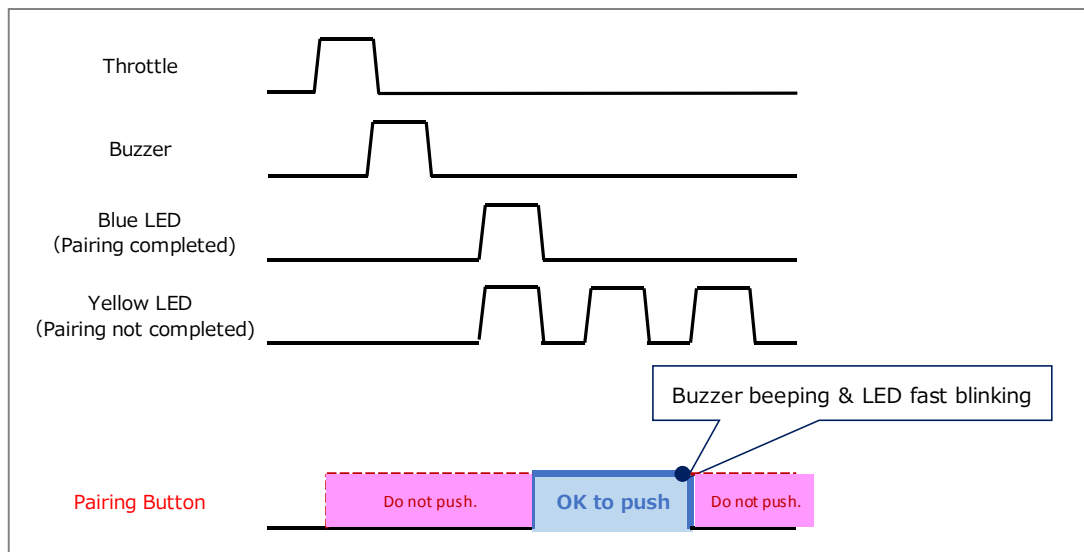

5.7. When the LED of the tool lights in red and goes off, the pairing is completed.

The wireless unit transmits the set value and the tool is ready to operate.

The LED of selected TOOL number on the wireless unit lights in green.

*1: If the LED lights in purple, pairing is failed. Carry out the steps as described in 5.6.

*2: Even if the battery pack is removed and inserted again, the pairing status is maintained.

6. Setting Method

Set values can be changed on the browser of your PC or PC-1.

For setting on the browser, follow the steps below.

For setting method by PC-1, see the Instruction Manual of PC-1.

* During the setting on the browser, do not set by PC-1.

6.1. Set the IP address of PC.

◆ In case of Windows XP

スタート → 設定 → ネットワーク接続
ローカル エリア接続で右クリックし、プロパティを選択。

インターネットプロトコル (TCP/IP) を選択し、プロパティを押す。

・ IP アドレス : 192.168.124.10
・ サブネットマスク : 255.255.255.0 を入力し、OKを押す。





◆ In case of Windows 7

コントロールパネル → ネットワークと共有センター → ローカル エリア接続をクリック

プロパティを押す。

インターネット プロトコルバージョン4 (TCP/IPv4) を選択し、プロパティを押す。

IP アドレス : 192.168.124.10
サブネットマスク : 255.255.255.0 を入力し、OKを押す。

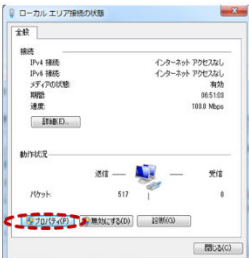
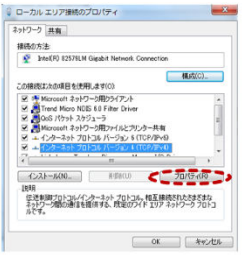
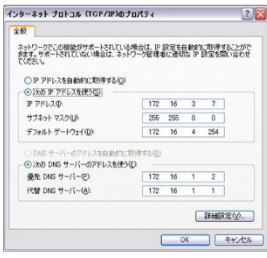
6.2. Connect this product and PC with LAN cross-cable.

6.3. Open the Internet Explorer.

6. 4. Enter “http://192.168.124.20/” and press Enter.

The browser is started.

Selecting English on right above, language is changed to English.



6.5. Select TOOL No. or WIRELESS UNIT for which the language and set values are read and written.

The setting screen is opened.

【Ex.】 “Tool 1 setting” is chosen (ENGLISH)

【Ex.】 ”Wireless unit” is chosen (ENGLISH)

6. 6. Read and write the set values according to the following steps.

Reading the set value: Select “read” and press “EXECUTE”.

Writing the set value: After the set value is changed, select “write” and press “EXECUTE”.

FINAL ANG. NG STOP	OFF	OFF
BOLT NUMBER	3	3

read
 write
 EXECUTE

* After you enter the value out of the entry limit range, if “write” is chosen and “EXECUTE” is pressed, the following error message appears and the set value is not changed.

YOKOTA
 YOKOTA INDUSTRIAL CO., LTD
 TOOL 1 SETTING SCREEN

***** ATTENTION *****

Please check setting data and retry to set new data.

It couldn't be update, because some input data was out of order.

***** ATTENTION *****

Tool 1 Settings

Error Message

7. Setting Items

7.1. Setting of tool 1 – 4

7.1.1. All work common setting items

Q'TY CONTROL

Set contents	Selection	Default
Setting ON/OFF of Q'TY CONTROL.	OFF ON	OFF

START CONDITON

Set contents	Selection	Default
Selecting the start condition of Q'TY CONTROL.	WORK S FASTN	WORK S
※ If the setting is changed, remove and insert the battery pack of the tool.		

WAITING

Set contents	Selection	Default
Selecting the operation after completion of the work.	STOP RUN	STOP

AUTO CLEAR

Set contents	Selection	Default
Setting AUTO CLEAR.	OFF ON	OFF

ON: When the remaining quantity becomes zero, it is cleared.

*This setting is valid only when the start condition is FASTN.

OFF : Even when the remaining quantity becomes zero, it is not cleared.

When PASS, RESET signal, or WORK S signal is entered, the remaining quantity is cleared.

END CONDITION

Set contents	Selection	Default
Selecting END CONDITION of Q'TY CONTROL.	END LS NUMBER	END LS

TOOL BUZZER

Set contents	Selection	Default
Setting ON/OFF of tool buzzer at tightening judgement.	OFF ON	ON

TOOL LAMP

Set contents	Selection	Default
Setting ON/OFF of tool lamp at tightening judgement.	OFF ON	ON

WORK SEL

Set contents	Selection	Default
Setting WORK SEL.	BIT : DATA :	BIT

WAVE DATA OUTPUT

Set contents	Selection	Default
Setting ON/OFF of WAVE DATA OUTPUT.	OFF	OFF
ON: Output from the tool to the wireless unit.	ON	

OFF: No output from the tool to the wireless unit.

* To send output to external device from the wireless unit, set "WAVE DATA DESTINATION" ON.

(see Cl. 7.2.3.3)

SLEEP TIME

Set contents	Selection	Default
Setting SLEEP TIME.	0-100 (min)	1

If "0" entered : Not sleep

* If YS-e controller board is before Ver.1.01, 0-10(min)

LIMIT WORK

Set contents	Selection	Default
Setting the number of work to be used.	1 : a 2 : a,b 3 : a,b,c 4 : a,b,c,d	1

ID SETTING

Set contents	Selection	Default
Setting the ID number of the tool.	0~9999	0000

7.1.2. Setting items for every work

START TRQ

Set contents	Selection	Default
Setting the value of start torque to be indicated. Set the value to be as follows: Upper limit torque \geq cut torque \geq lower limit torque \geq start torque.	0.0~999.0(N·m)	3.0N·m

SWITCH TRQ

Set contents	Selection	Default
Set the torque to switch from motor mid-speed to motor high speed.	0.0~999.0(N·m)	3.0N·m

MIN TRQ

Set contents	Selection	Default
Setting the lower limit of torque. Set the value to be as follows: Upper limit torque \geq cut torque \geq lower limit torque \geq start torque.	0.0~999.0(N·m)	3.0N·m

CUT TRQ

Set contents	Selection	Default
Setting cut torque. Set the value to be as follows: Upper limit torque \geq cut torque \geq lower limit torque \geq start torque.	0.0~999.0(N·m)	3.0N·m

MAX TRQ

Set contents	Selection	Default
Setting the upper limit torque. Set the value to be as follows: Upper limit torque \geq cut torque \geq lower limit torque \geq start torque.	0.0~999.0(N·m)	3.0N·m

FREERUNNING ANG MIN

Set contents	Selection	Default
Setting the lower limit of free-running angle Set the value to be as follows: Upper limit of free-running angle \geq lower limit of free-running angle.	0~30000 (°)	0

FREERUNNING ANG MAX

Set contents	Selection	Default
Setting the upper limit of free-running angle. Set the value to be as follows: Upper limit of free-running angle \geq lower limit of free-running angle.	0~30000 (°)	30000

FINAL ANG MIN

Set contents	Selection	Default
Setting the lower limit of final angle. Set the value to be as follows: Upper limit of final angle \geq lower limit of final angle.	0~9999 (°)	0

FINAL ANG MAX

Set contents	Selection	Default
Setting the upper limit of final angle. Set the value to be as follows: Upper limit of final angle \geq lower limit of final angle.	0~9999 (°)	9999

STOP ABORT TIME

Set contents	Selection	Default
Setting the free running stop abort time.	0.1~0.5 (s)	0.10

MOTOR LOW SPEED

Set contents	Selection	Default
Setting motor low speed.	1200~1500(rpm)	1200

MOTOR MIDDLE SPEED

Set contents	Selection	Default
Setting motor middle speed.	1500~3000(rpm)	2000

MOTOR HIGH SPEED

Set contents	Selection	Default
Setting motor high speed.	1500~4800(rpm)	3000

JUDGE TIME

Set contents	Selection	Default
Setting judge time.	0.02~0.99(s)	0.50

BOLT CO-EFFICIENT

Set contents	Selection	Default
Setting bolt coefficient.	0.60~1.50	1.00

AVERAGE NUM.

Set contents	Selection	Default
Setting average number.	1~6	3

AVERAGE MODE

Set contents	Selection	Default
Selecting average mode.	CONT	CONT
CONT: Averaging continuous data	PEAK	
PEAK: Averaging by extracting data for average number from peak value.		

SKIP NUM.

Set contents	Selection	Default
Setting skip number.	0~5	2

SLOW ER NO.

Set contents	Selection	Default
Setting slow error number.	10~50	20

COMPEMC NUM.

Set contents	Selection	Default
Setting compensation number.	0~5	0

Torque is also measured throughout compensation number.

FREERUNNING NG STOP

Set contents	Selection	Default
Setting ON/OFF of free-running NG stop.	OFF	OFF
ON: In the event of free-running angle NG, the tool stops.	ON	
OFF: In the event of free-running angle NG, the tool does not stop.		

FINAL ANG. NG STOP

Set contents	Selection	Default
Setting ON/OFF of final angle NG stop.	OFF	OFF
ON: In the event of final angle NG, the tool stop.	ON	
OFF: In the event of final angle NG, the tool does not stop.		

BOLT NUMBER

Set contents	Selection	Default
Setting bolt number under quantity control.	0~99	2

7.2. WIRELESS UNIT

7.2.1. INPUT ALLOCATION

INPUT ALLOCATION

Set contents	Selection	Default
Assign any of WORKa, WORKb, WORKc, WORKd, Tool stop (OFF), PASS, RESET, or END to input terminal 1 to 8, respectively.	WORKa:0~8	WORKa:0
If "0" is entered, nothing is assigned.	WORKb:0~8	WORKb:0
Assignment can be made to TOOL1, TOOL2, TOOL3, and TOOL4 respectively.	WORKc:0~8	WORKc:0
For terminal numbers, see Chapter 8.	WORKd:0~8	WORKd:0
	Tool OFF:0~8	Tool OFF:0
	PASS:0~8	PASS:0
	RESET:0~8	RESET:0
	END:0~8	END:0

7.2.2. RELAY ALLOCATION

RELAY ALLOCATION

Set contents	Selection	Default
Assign any of NG, OK, OVER, UNDER, SLOW, Count NG, PASS, SLOW2, WORKa finish, WORKb finish, WORKc finish, WORKd finish, Select WORKa, Select WORKb, Select WORKc, or Select WORKd to output terminal 1 to 8, respectively.	NG:0~8	NG:0
If "0" is entered, nothing is assigned.	OK:0~8	OK:0
Assignment can be made to TOOL1, TOOL2, TOOL3, and TOOL4 respectively.	OVER:0~8	OVER:0
For terminal numbers, see Chapter 8.	UNDER:0~8	UNDER:0
	SLOW:0~8	SLOW:0
	COUNT NG:0~8	COUNT NG:0
	PASS:0~8	PASS:0
	SLOW2:0~8	SLOW2:0
	WORK a Fin:0~8	WORK a Fin:0
	WORK b Fin:0~8	WORK b Fin:0
	WORK c Fin:0~8	WORK c Fin:0
	WORK d Fin:0~8	WORK d Fin:0
	WORK a Sel:0~8	WORK a Sel:0
	WORK b Sel:0~8	WORK b Sel:0
	WORK c Sel:0~8	WORK c Sel:0
	WORK d Sel:0~8	WORK d Sel:0

7.2.2.1. RELAY TIME

WORK FIN

Set contents	Selection	Default
Setting work finish output time.	0.0~9.9(s)	0.0
If 0,0 is selected, outputting is continued.		

WORK SEL

Set contents	Selection	Default
Setting work select output time.	0.0~9.9(s)	0.0
If 0,0 is selected, outputting is continued.		

COUNT NG

Set contents	Selection	Default
Setting count NG output time.	0.0~9.9(s)	0.0
If 0,0 is selected, outputting is continued.		

OK

Set contents	Selection	Default
Setting OK output time.	0.0~9.9(s)	0.0
If 0,0 is selected, outputting is continued.		

OVER

Set contents	Selection	Default
Setting OVER output time.	0.0~9.9(s)	0.0
If 0,0 is selected, outputting is continued.		

OTHER RY

Set contents	Selection	Default
Setting other signal output time.	0.0~9.9(s)	0.0
If 0,0 is selected, outputting is continued.		

7.2.3. COMMUNICATION

7.2.3.1. SERIAL

BAUD RATE

Set contents	Selection	Default
Selecting baud rate.	2400	9600
	4800	
	9600	
	19200	
	38400	
	115200	

PARITY

Set contents	Selection	Default
Setting parity.	NON	NON
	EVN	
	ODD	

7.2.3.2. LAN

IP ADDRESS

Set contents	Selection	Default
Designating IP address.	000.000.000.000	192.168.124.020
<i>After change, reboot the wireless unit.</i>	~255.255.255.255	

SUBNET MASK

Set contents	Selection	Default
Entering subnet mask.	000.000.000.000	255.255.255.0
<i>After change, reboot the wireless unit.</i>	~255.255.255.255	

PORT NO.

Set contents	Selection	Default
Setting port number.	0~65535	10001
<i>After change, reboot the wireless unit.</i>		

7.2.3.3. OUTPUT DESTINATION

RUNDOWN DATA

Set contents	Selection	Default
Setting ON/OFF of SERIAL and LAN output of rundown data per piece.	OFF	SERIAL : ON
	ON	LAN : OFF

WAVE DATA

Set contents	Selection	Default
Setting ON/OFF of serial output of wave data.	OFF	SERIAL : OFF
ON: Wave data is outputted from the wireless unit to external device.	ON	

OFF: Wave data is not outputted from the wireless unit to external device.

* Before setting to ON, make sure that "WAVE DATA OUTPUT" is ON (see Cl.

7.1.1.1).

ID NO. PRINT

Set contents	Selection	Default
Setting ON/OFF of LAN output of ID number.	OFF	LAN : OFF
ON: ID number is printed.	ON	
OFF: ID number is not printed.		

7.2.3.4. RUNDOWN PRINT FORMAT

TOOL NUM PRINT

Set contents	Selection	Default
Setting ON/OFF of printing of tool number for rundown.	OFF	ON
ON: Tool number is printed.	ON	
OFF: Tool number is not printed.		

REMAIN PRINT

Set contents	Selection	Default
Setting ON/OFF of remain print for rundown results.	OFF	ON
ON: Remaining quantity is printed.	ON	
OFF: Remaining quantity is not printed.		

PLUS PRINT

Set contents	Selection	Default
Setting ON/OFF of pulse print for rundown results.	OFF	ON
ON: Tightening pulse is printed.	ON	
OFF: Tightening pulse is not printed.		

DATE PRINT

Set contents	Selection	Default
Setting ON/OFF of date print for rundown results.	OFF	ON
ON: Date is printed.	ON	
OFF: Date is not printed.		

FIXED PRINT

Set contents	Selection	Default
Setting fixed length/variable length for printing of rundown results.	OFF	ON
ON: Printing in fixed length.	ON	
OFF: Printing in variable length.		

8. Judgement of tightening

- ① Judging that the result of tightening is in the set range after tightening.
- ② If the result is in the set range, OK of tightening judgment lamp lights up.

If any defect is detected, the contents of the defect are displayed in the tightening result.

Detection of abnormality

Abnormal tightening is as described below.

- Galling : Foreign matter enters between female and male screws and tightening torque increases without generation of clamp force.
 - Seizure : It occurs when part of thread of male or female screw is stripped. Tightening torque increases since tightening is proceeded while threads are being stripped.
 - Slantwise screwing: This is a phenomenon that a bolt is slantwise screwed into female screw, because of position gap between the axis of bolt and that of female screw or of angle shift. Tightening torque increases without generation of clamp force.
 - Over-tightening: Bolt is tightened with excessive torque.
 - Under-tightening: Bolt is tightened with insufficient torque.
 - Lack of quantity of tightened bolt: Lack in quantity of tightened bolt.
- ① Torque error (indication of judgment of tightening)
 - OVER : Over-tightened.
 - UNDER : Under-tightened.
 - ② Pulse number error (indication of judgment of tightening)
 - SLOW ER. : Number of pulse required for tightening exceeds the SLOW ER. number.

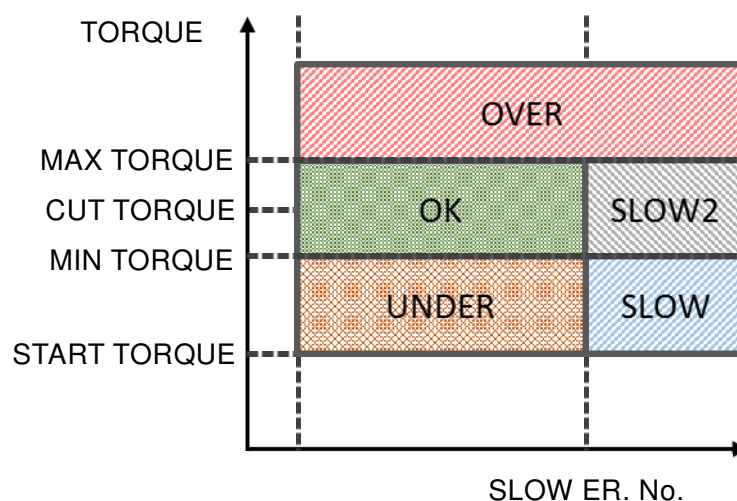

③ Bolt number error (indication of error)

- COUNT NG : Lack of number of tightened bolts against the set number.

④ Angle NG (indication of judgment of tightening)

[Free-running angle NG]

- N31: Lack in free-running angle.
- N32: Excess in free-running angle.

[Tightening angle NG]

- N35: Lack in tightening angle.
- N37: Excess in tightening angle.

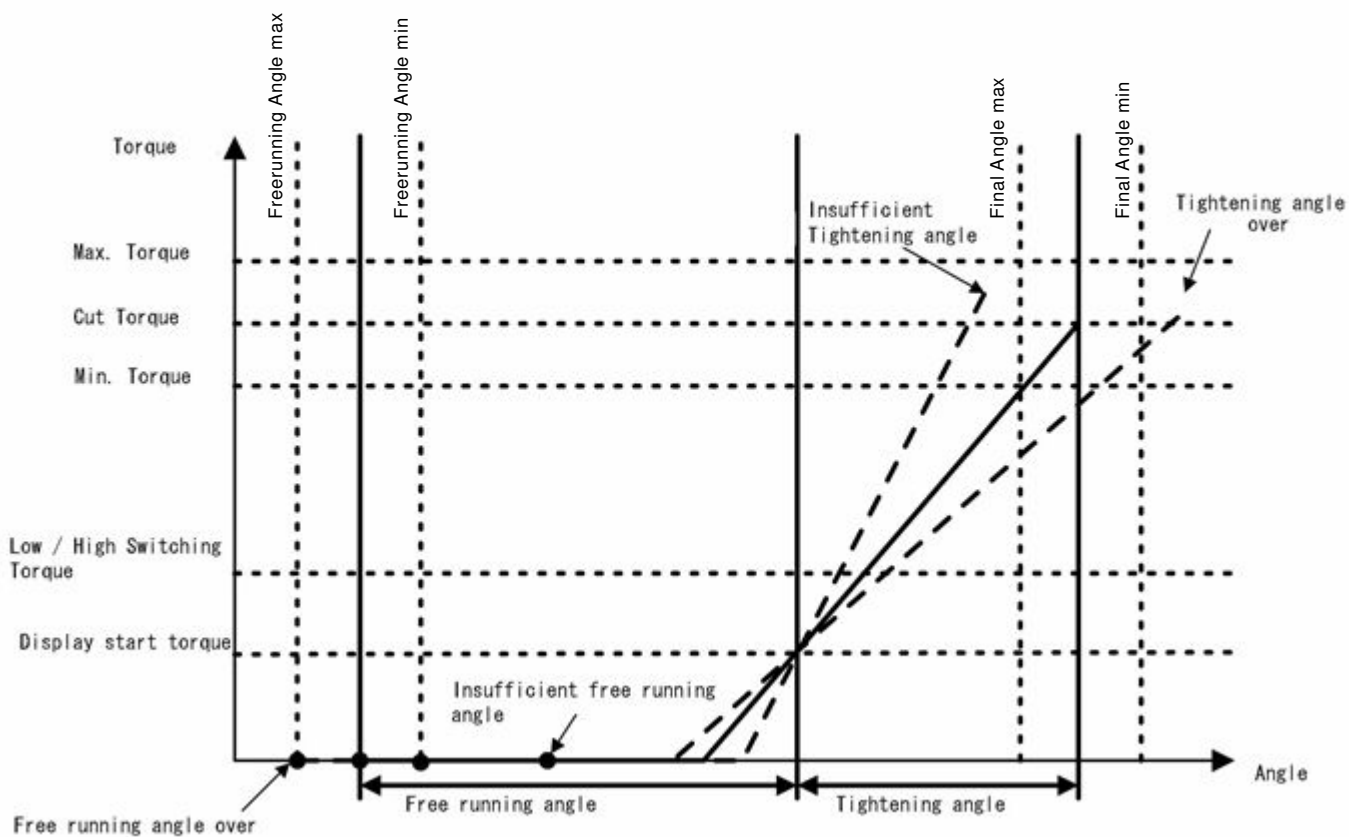

9. Assignment of output relay and input terminal



No.	Pin assignment	Pin assignment	No.
13	RY1	+24V	1
14	RY1-RY2 COM	+24V	2
15	RY2	IN COM	3
16	RY3	IN 1	4
17	RY3-RY4 COM	IN 2	5
18	RY4	IN 3	6
19	RY5	IN 4	7
20	RY5-RY6 COM	IN 5	8
21	RY6	IN 6	9
22	RY7	IN 7	10
23	RY7-RY8 COM	IN 8	11
24	RY8	24V return	12

Terminal Block Connecting Diagram

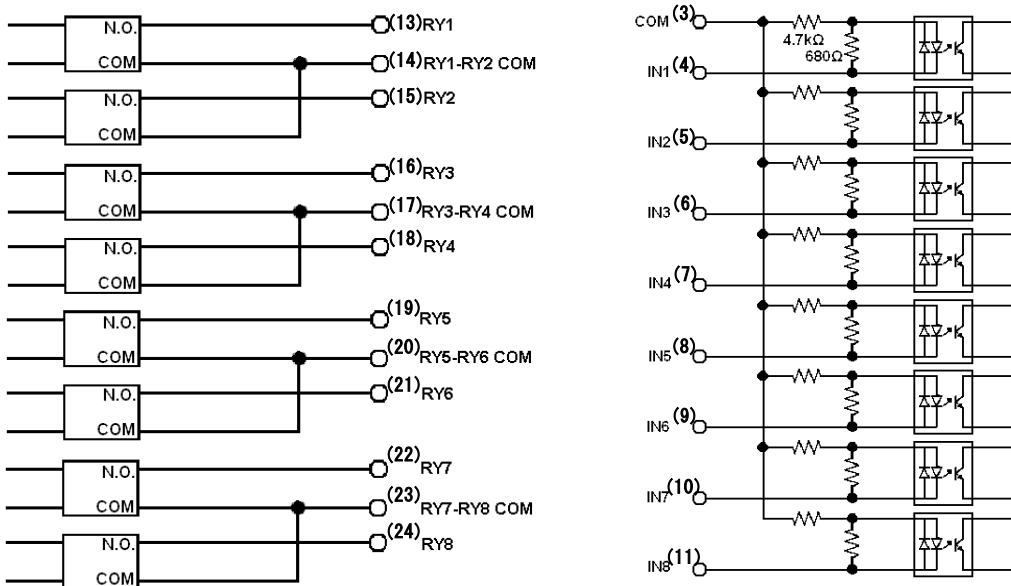

- * Current capacity available from DC 24V (Pin 1 and 2, 12) is max. 100mA in total.
- * Since the Photocoupler is bi-directional, both interfaces, i.e. NPN (sink) and PNP (sourcing), are available depending on the connection of COM.
- * When connecting with NPN output, add the wire between No. 2 (+24V) and No. 3 (IN COM). See the left figure below.
When connecting with PNP output, add the wire between No. 3 (IN COM) and No. 12 (24V return). See the right figure below.
- * Terminal block: Main unit: 163391000,
Wire connector: 1606740000, 1640030000 (manufactured by Weidmuller), one each used

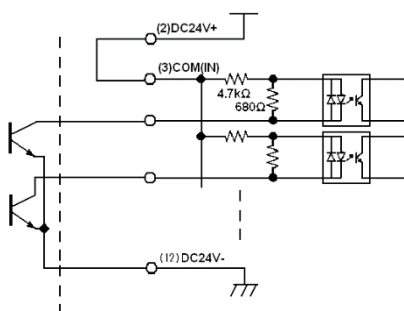

NPN connection

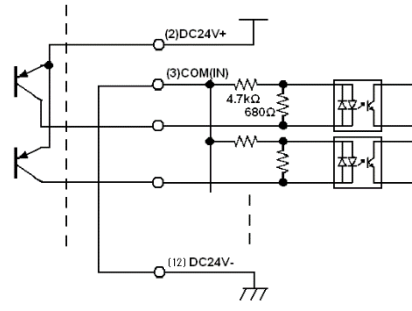

PNP connection

10. Maintenance and Inspection

 Before maintenance and inspection of this product, read carefully and understand Chapter 1 “Safety Precautions”, especially the section of Built-in Battery in “■ Maintenance · Inspection · Repair” and carry out correctly.

10.1. Replacement of battery

This product contains lithium battery for memory of clock.

Replacement period of battery is shown on the under side of the unit.

When the replacement period is coming, ask us or our designated servicing factory for replacement via your sales outlet or sales agent.

If you replace the battery by yourself, ask your electric professional to replace it according to the following.

(Procurement of battery)

Be sure to procure the battery (CR-2032, Panasonic) for wireless unit via your sales outlet or sales agent.

*** Never modify and use other battery.**

(Procedure of battery replacement)

- ① Turn off the power switch of the wireless unit and remove the power plug from the receptacle.
- ② Leave the unit for one hour to cool down hot parts in the unit.
- ③ Again, make sure that the power switch is OFF and the power plug is removed from the receptacle.
- ④ Remove the cover fixing screws on the side of the unit (four locations) and remove the cover (see ① to ④).

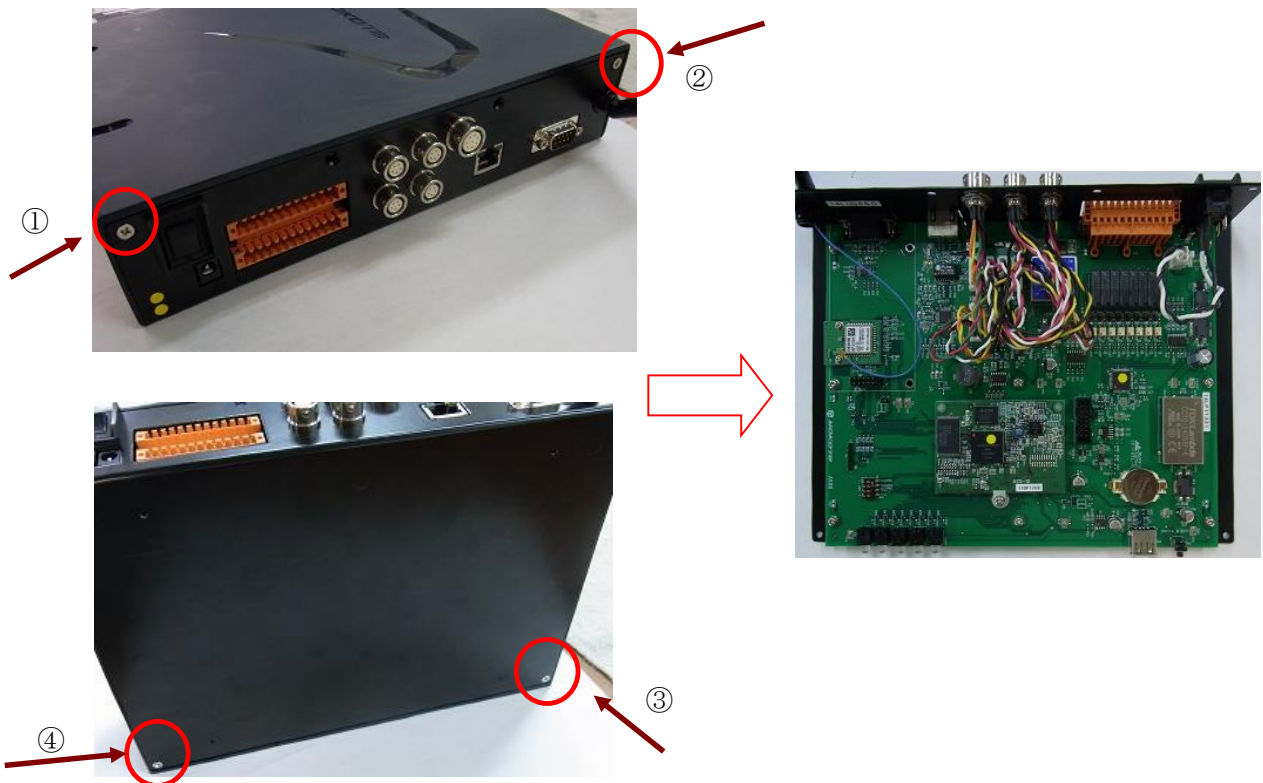

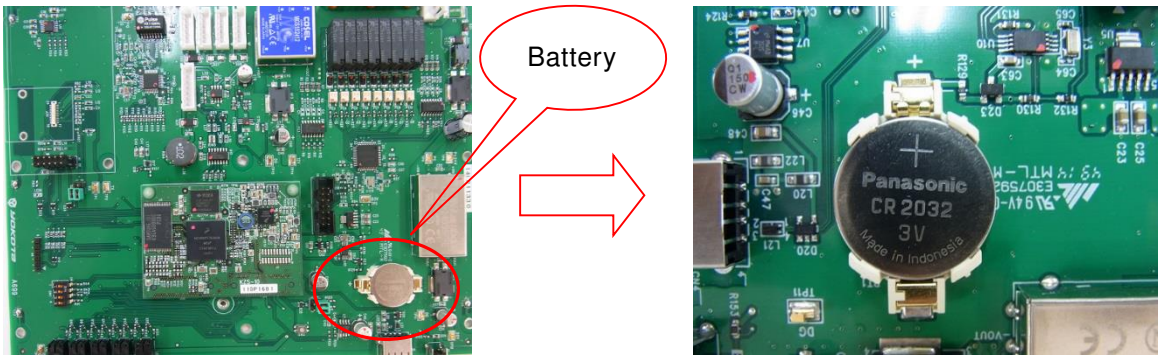

⑤ Remove the old battery.



⑥ Install a new battery.

* Make sure to install correctly the positive and negative poles of the battery. The positive pole is top face and the negative is the bottom face.

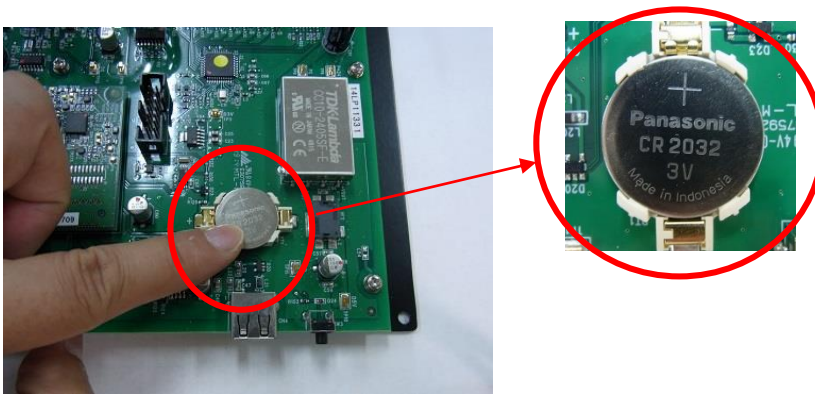

⑦ Install the cover and tighten the four screws.

⑧ Update the battery replacement period on the bottom face six years after.

Example:

BAT.CHANGE : Apr 2015

BAT.CHANGE : Apr 2021



⑨ Make sure that the power switch is OFF and then connect the power plug to the receptacle.

⑩ Turn on the power switch.

⑪ Set the date by PC-1 again.

11. Troubleshooting

Before asking repair, carry out the following checks.

If the trouble cannot be solved by the following actions, or if other trouble occurs, stop using this product immediately, and be sure to ask us or our qualified (designated) servicing factory via your sales outlet or sales agent.

Trouble	Probable cause	Action
Power LED is not ON, though the power switch is ON	The power plug is not inserted into the receptacle.	Insert the power plug into the receptacle.
	The power supply cord is not connected.	Insert the power supply cord into the wireless unit firmly.
No transition to pairing mode	The power plug is not inserted into the receptacle.	Insert the power plug into the receptacle.
	The power supply cord is not connected.	Insert the power supply cord into the wireless unit firmly.
	Pressing time for pairing button is too short.	Press the button until the LED of selected TOOL No. blinks fast in red.
Pairing is not possible	Battery pack is not installed in the tool.	Install the battery pack in the tool.
	The power of the wireless unit is not ON.	Turn on the power to the wireless unit.
	The tool does not shift to pairing mode.	Press the pairing button of the tool for a while until the tool shifts to pairing mode.
	The wireless unit does not shift to pairing mode.	Press the pairing button of the wireless unit for a while until the wireless unit shifts to pairing mode.
	The distance between the tool and the wireless unit is long.	Get the tool and the wireless unit closer and carry out pairing again.
	There is an obstacle between the tool and the wireless unit.	Check the surrounding working environment.
The tool does not operate.	The wireless unit is not turned on.	Turn on the wireless unit.
	Pairing with the wireless unit is not established.	Carry out pairing.
	The motor is overheated.	Wait until the motor gets cool and the LED goes off.
	The driver is overheated.	Wait until the driver gets cool and the LED goes off.
	The battery pack is over-discharged.	The battery voltage falls below a certain level and protective function is active. Charge the battery pack. * Be sure to charge the over-discharged battery pack to full level. If the charging level is not sufficient, the protective function may not be released.

The tool does not automatically stop	The value of cut torque is not proper.	Set the cut torque again.
“OVER” frequently occurs	The upper limit of torque is not proper.	Set the upper limit of torque again.
	Tightening capability of the tool is not proper.	Set the rotation speed again or replace the tool with low torque range.
“UNDER” frequently occurs	The lower limit of torque is not proper.	Set the lower limit of torque again.
	During tightening, the hand is off the throttle lever of the tool.	Pull the throttle lever until the tool automatically stops.
	The tightening capability of the tool is not proper.	Set the rotation speed again or replace with the tool with high torque range.
The signal is not inputted to input terminal	Improper connection on the terminal block.	Carry out connection so that the number marked on the unit matches with the number on the terminal block.
	The setting of input terminals is wrong.	Carry out setting of input terminals again.
	Cable is broken.	Replace the cable for external signal.
The signal is not outputted from output terminal	Improper connection on the terminal block.	Carry out connection so that the number marked on the unit matches with the number on the terminal block.
	The setting of output terminals is wrong.	Carry out setting of output terminals again.
	Cable is broken.	Replace the cable for external signal.
DS-1 does not operate	The wireless unit is not ON.	Turn on the wireless unit.
	Cable is not connected.	Connect the cable.
	Cable is broken.	Replace the cable.
PC-1 does not operate	The wireless unit is not ON.	Turn on the wireless unit.
	Cable is not connected.	Connect the cable.
	Cable is broken.	Replace the cable.
RS-232C communication cannot be made	RS-232C cable is not connected to the wireless unit.	Connect RS-232C cable to SERIAL terminal on the back of the wireless unit.
	Communication speed of the wireless unit and device to be connected, parity check, existence of flow control are not set.	Set the communication speed of the wireless unit and device to be connected, parity check, existence of flow control
	Straight cable is used.	Use a cross cable.
LAN communication cannot be made	LAN cable is not connected to the wireless unit.	Connect LAN cable to LAN terminal on the back of the wireless unit.
	IP address, port number, and subnet mask of the wireless unit are not set.	Set the IP address, port number, and subnet mask of the wireless unit.
	Straight cable is used.	Use a cross cable.

12. External View

